

JOIDES Journal

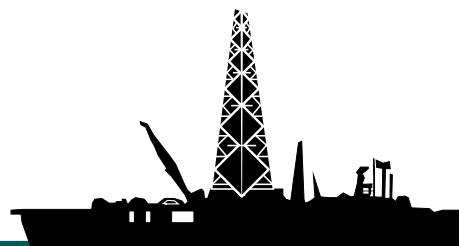

Volume 24 Number 2/Fall 1998

In this Issue:

30 YEARS OF OCEAN DRILLING

Entering the 30-Something Years 2

SCIENCE — Recent Leg Reports

Southern Ocean Paleooceanography: Preliminary Results from Leg 177..... 4

Antarctic Glacial History and Sea-Level Change — Leg 178 Samples Antarctic Peninsula Margin Sediments..... 7

A Long Gabbro Section in the Ocean Crust: Results of Leg 176 Drilling, Southwest Indian Ridge 11

SCIENCE/TECHNOLOGY — Recent Leg Reports

Leg 179: Hole 1105A and NERO Hole 1107A..... 15

Hammer Drill: An Overview and Post Leg 179 Update..... 19

MWC in ODP — Success During Leg 179 and the Road Ahead..... 22

TECHNOLOGY

Activation of the Drill String Compensator on Board the JOIDES Resolution 25

A Dry Dock for the JOIDES Resolution..... 28

Riser Drilling Technology for an Integrated Ocean Drilling Program (IODP)..... 31

INTERNATIONAL GEOSCIENCE INITIATIVES

PAGES — Past Global Changes..... 34

PLANNING

A Message from the Chair..... 36

EXCOM Adopts New Policy on Associate Membership 37

The FY'00 Science Plan: Legs 188–193 38

Through the Labyrinth of ODP's Proposal Cycle 41

JOIDES Resolution Operations Schedule: 1999–2000 44

The Vancouver Conference 45

AGU Fall Meeting: ODP Related Sessions 46

Upcoming Meetings 47

Announcements 48

ODP Contractors/Member Countries/Consortia Inside Back Cover

Entering the 30–Something Years

by *Kate Moran*

The Ocean Drilling Program, and its predecessor, the Deep Sea Drilling Project, will complete 30 years of scientific ocean drilling this year with an outstanding record of achievements. I am very proud to have been associated with the program, previously as an active science participant and now as the new Director of the Ocean Drilling Program at JOI.

DSDP officially began in 1968 when the *Glomar Challenger* sailed on its first scientific drilling expedition to the Gulf of Mexico and the Bermuda Rise. In addition to the major engineering feat of this first voyage — drilling in water depths greater than 5000 m and penetrating 700 m into the seafloor — the science successes were outstanding. Scientists recovered the oldest rocks ever found in the deep ocean and discovered deep water petroleum and salt dome cap rock. But scientific ocean drilling began even earlier than DSDP: in 1961, when the vessel, *CUSS I*, was chartered and drilled 200 m into the seafloor in 3,800 m of water off Guadeloupe Island. The recovery of basalt in this first hole verified the composition of Layer 2, and demonstrated that ocean drilling was indeed critical for the advancement of science.

The early days of scientific drilling in the DSDP were also remarkable from a technological standpoint because we were drilling in the deepest parts of our oceans, in water depths to which the oil industry is just now moving 30 years later. And technology development did not stop at the deep water achievement alone. One of the most successful tools developed by the Program, the hydraulic piston corer, has proved to be a keystone in the field of paleoceanography. Indeed, we now know that climate cycles are controlled by the very regular and predictable variations in the Earth's orbital geometry because of the studies that were done on sediment collected with the piston corer. This understanding represents one of the greatest geoscience success stories of this century.

ODP began in 1985 with a newer and more capable drillship, and greater international participation. The ODP over the past 13 years represents an era of outstanding scientific achievements. These achievements are broad in scope, ranging from the

recovery of sediment records that represent ultra-high resolution climate records, to exploration of gas hydrates in deep water settings, to the discovery of fluid flow in accretionary complexes and in oceanic lithosphere. Recently, the ODP drilled and recovered a most remarkable sediment section that recorded the meteorite impact at the K-T boundary: the deposition of the 'fall-out' resulting from the impact; the absence of life following; and then the gradual recovery of life to the oceans. Over the past few years, the ODP has discovered that the Earth's biosphere extends into and far below the seafloor, a discovery that has far-reaching and broad science implications. Understanding life in these extreme environments will open up many new areas of research that could have a significant effect on societal issues.

Phase III of scientific ocean drilling will end in 2003 when ODP ends. Clearly, the achievements to date and the scientific needs justify continuation of ocean drilling post-2003. The remaining five years of the ODP and its successor program represent a key component of the exploration of our dynamic earth. The ODP/DSDP picture of this planet has been slowly coming into better focus. Although not yet a crisp view, the clearer picture has strongly convinced the science community that these efforts must continue. We must continue to explore the global ocean from shallow to deep, equator to pole. We must study our ever-expanding biosphere. We must move into unexplored reaches of the oceans, including deep into the crust and into regions of the Arctic. Without the knowledge gained from these efforts to understand the basic processes of our own planet, critical environmental, resource, and natural hazard decisions relevant to society cannot be well formed. Our future drilling must include increased focus on climate change, earthquakes and seismicity, and the biosphere.

So, now that we are 30-something, it is time to plan for the most productive years yet to come. We at JOI, TAMU, and LDEO look forward to working with the JOIDES science community in the next five years to continue the ODP successes and to plan for a broader and even more exciting program post-2003. ❖

ODP Welcomes its New Director at JOI!



Dr. Kathryn Moran assumed her position as the new Director of ODP at JOI on June 19th, 1998. Kate came to JOI from the Bedford Institute of Oceanography where she has served as a Research Engineer for the Geological Survey of Canada since 1983. She graduated from the Technical University of Nova Scotia (Dalhousie, Halifax) with a Ph.D. in Civil Engineering. She also received a M.Sc. in Ocean Engineering from the University of Rhode Island and a B.Sc. in Civil Engineering from the University of Pittsburgh.

Kate brings to this position a detailed knowledge of ODP through her participation as both a shipboard and shorebased scientist — she has sailed on five *JOIDES Resolution* legs since 1986. As a geotechnical and physical properties specialist, Kate was Chair of the JOIDES Shipboard Measurements Panel from 1989-1993, and most recently of the JANUS Steering Committee.

She brings to the Directorship position at JOI a strong commitment to the future of international scientific ocean drilling. We look forward to her leadership into the next millenium!

DSDP and ODP Drill Sites 1968 - 1998

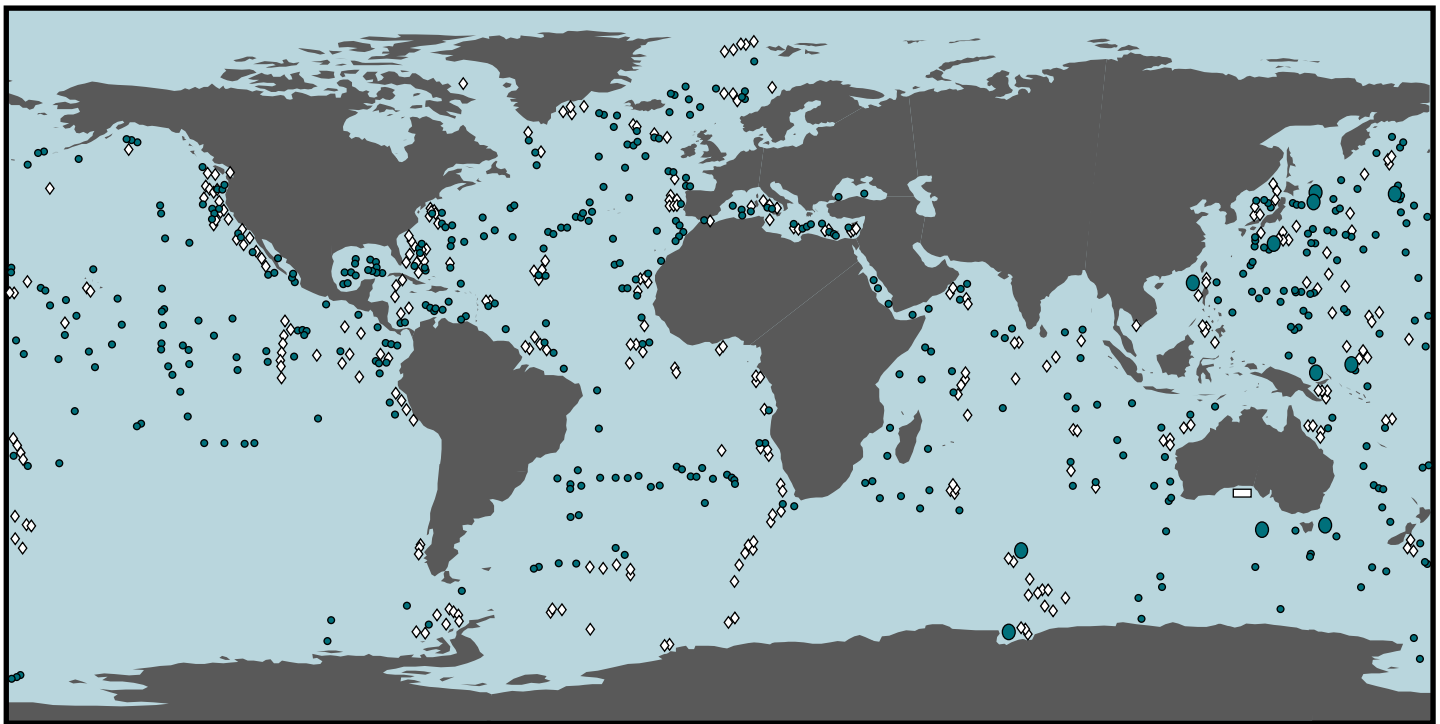

- Deep Sea Drilling Project (DSDP) Sites
- ◊ Ocean Drilling Program (ODP) Sites
- ◻ Current Operations Area
- Scheduled Legs FY'99 / FY'00

The *Glomar Challenger* (cover: center & left) was used by DSDP between 1968 - 1983 and completed 96 legs. The ship traveled over 600,000 km and recovered more than 97 km of core. The first ODP cruise with the *JOIDES Resolution* (cover: right) began in January 1985 and up to present has collected more than 168 km of core material. The ship is now in the Great Australian Bight drilling ODP Leg 182.

(Cover: photos of the *Glomar Challenger* courtesy of Scripps Institution of Oceanography, San Diego, CA; photo of the *JOIDES Resolution* provided by ODP-TAMU).

Southern Ocean Paleoceanography: Preliminary Results from Leg 177

by David Hodell, Rainer Gersonde, Peter Blum and the Leg 177 Scientific Party

The Antarctic ice sheets and the adjacent Southern Ocean play a vital role in defining Earth's climate system, yet many questions remain regarding the paleoceanographic and paleoclimatic history of this remote region of the world's oceans. Our efforts at reconstructing paleoceanographic change in this climatically important region has been hampered by the lack of suitable core material for high-resolution studies of continuous sedimentary sequences. To address this shortcoming, Leg 177 sailed from Capetown, South Africa, in mid-December 1997 to the subantarctic South Atlantic and drilled seven sites along a north-south transect across the Antarctic Circumpolar Current (ACC) from 41° to 53°S (Fig. 1). The ambitious goal of Leg 177 is to understand the role of the Southern Ocean in climate change on time scales ranging from millennia to tens of millions of years. During Leg 177, we were blessed with relatively good weather by Southern Ocean standards, and more than 4000 m of sediment was recovered ranging in age from the middle Eocene to the Holocene. This

abbreviated leg report cannot begin to capture the full breadth of our scientific results, so we focus here on four specific highlights of Leg 177 science, including the recovery of:

- a 330-m section of middle Eocene to lower Miocene sediments in Site 1090 that is shallowly buried and was recovered in multiple holes;
- a high-resolution transect of complete and expanded Plio-Pleistocene sequences at 41° (Site 1089), 47° (Site 1091), 50° (Site 1093), and 53°S (Site 1094);
- laminated diatom mats in some cored intervals of southern Sites 1091, 1093 and 1094, which provide the opportunity to reconstruct paleoclimatic signals on centennial time scales for certain time periods; and
- young porcellanite horizons in late Pleistocene diatom ooze (~400 kyrs) at Site 1094, representing very early silica diagenesis at low (near bottom-water) temperature.

Figure 1: Locations of Leg 177 drill sites and previous ODP and DSDP sites in the South Atlantic relative to major frontal boundaries.

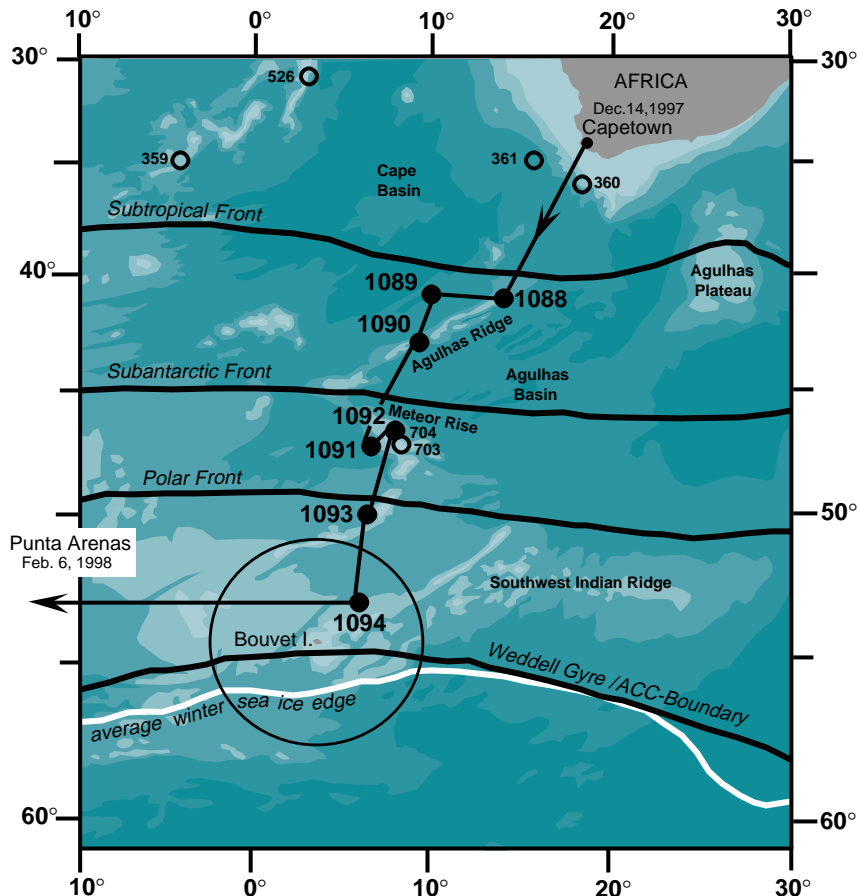

Middle Eocene to Early Miocene Southern Ocean Paleoceanography

At a depth of ~70 m at Site 1090, we encountered a hiatus marked by a striking color change from white nannofossil ooze to reddish mud-rich nannofossil ooze (Fig. 2). Early Pliocene sediments above the hiatus contain manganese nodules and sediments below the hiatus are early Miocene in age and contain a tephra sequence composed of vitric ash admixed with hemipelagic material. We did not anticipate the long duration of this hiatus (~15 m.y.), but were pleased to recover early Miocene and Oligocene sediments using the APC in multiple holes, providing the opportunity to construct a complete composite section. The paleomagnetic reversal stratigraphy is excellent at Site 1090, even in the cores that were recovered by XCB, and this section will likely become a deep-sea type section for biomagnetostratigraphic correlations (Fig. 2). The potential also exists for developing an astronomically-tuned time scale using cyclic variations in lithologic parameters, similar to that developed during Leg 154 (Weedon et al., 1997). Due to the shallow burial of the section at Site 1090, oxygen isotopic compositions of foraminifers will not be compromised by diagenetic alteration and will thus provide valuable information about the paleoceanographic evolution of the Southern Ocean. The middle Eocene to early Miocene se-

quence at Site 1090 is especially significant because it spans the time period associated with the development of ice-sheets on Antarctica, early production of cold surface and bottom waters in the Southern Ocean, and paleogeographic changes (e.g., opening of the Tasman Seaway and Drake Passage) that led to the establishment of the ACC (Kennett, 1977).

High-Resolution Plio-Pleistocene Transect

Undoubtedly, one of the most exciting results of Leg 177 was the successful recovery of expanded Plio-Pleistocene sequences in Sites 1089, 1091, 1093 and 1094 arrayed across the ACC from 41° to 53°S (Fig. 1). This transect of sites was designed to encompass the past dynamic range of the Polar Front and Antarctic sea-ice field, and is necessary to capture the complexity of strong surface water gradients occurring in this region. Average sedimentation rates in the four sites during the Brunhes Chron (last 780 kyrs) varied from 13.2 cm/kyr at Site 1089, to ~14 cm/kyr at Site 1094, ~14.5 cm/kyr at Site 1091, and ~25 cm/kyr at Site 1093. The high sedimentation rates in each of the drilled sites will resolve climate variability on a millennial time scale. These cores represent the marine sediment analogs of continental ice cores, and are matched by similar sequences recovered from sediment drift deposits in the North Atlantic.

Variations in color reflectance, collected with the Split Core Analysis Track (SCAT; see Ortiz et al., 1998), were tremendously useful during Leg 177 for estimating the position of marine isotope stages (MISs) during the late Pleistocene. Using this method, it was possible to infer preliminary isotopic stage boundaries (Fig. 3) because the transitions from glacial to interglacial stages in the Southern Ocean are marked by increased carbonate content and peaks in sediment brightness (oxygen isotope measurements are underway to confirm these interpretations). Previous isotopic work has demonstrated that a direct link can be established between subantarctic planktic oxygen isotopic signals and Antarctic ice core records (specifically Vostok) for the last 80 kyrs (Charles et al., 1996). Leg 177 cores will permit us to extend marine sediment-ice core correlations to the oldest ice at Vostok, which is now approximately 450 kyrs (Fig. 3), and study the interaction between the ocean, the polar atmosphere and the Antarctic cryosphere. Additionally, correlation of Leg 177 sites with comparable cores drilled during Legs 162 and 172 on North Atlantic drift deposits will aid in identifying the mechanism(s) linking climate in the polar regions of the Atlantic.

Laminated Diatom Mats

One of the most remarkable lithologies recovered in the high-latitude sites during Leg 177 were laminated diatom mats consisting largely of the needle-shaped diatom *Thalassiothrix*. The mats occur as intervals of laminated sediment as much as 20-m thick, as intermittently laminated sediment, or as bioturbated mat fragments or burrow-fills of

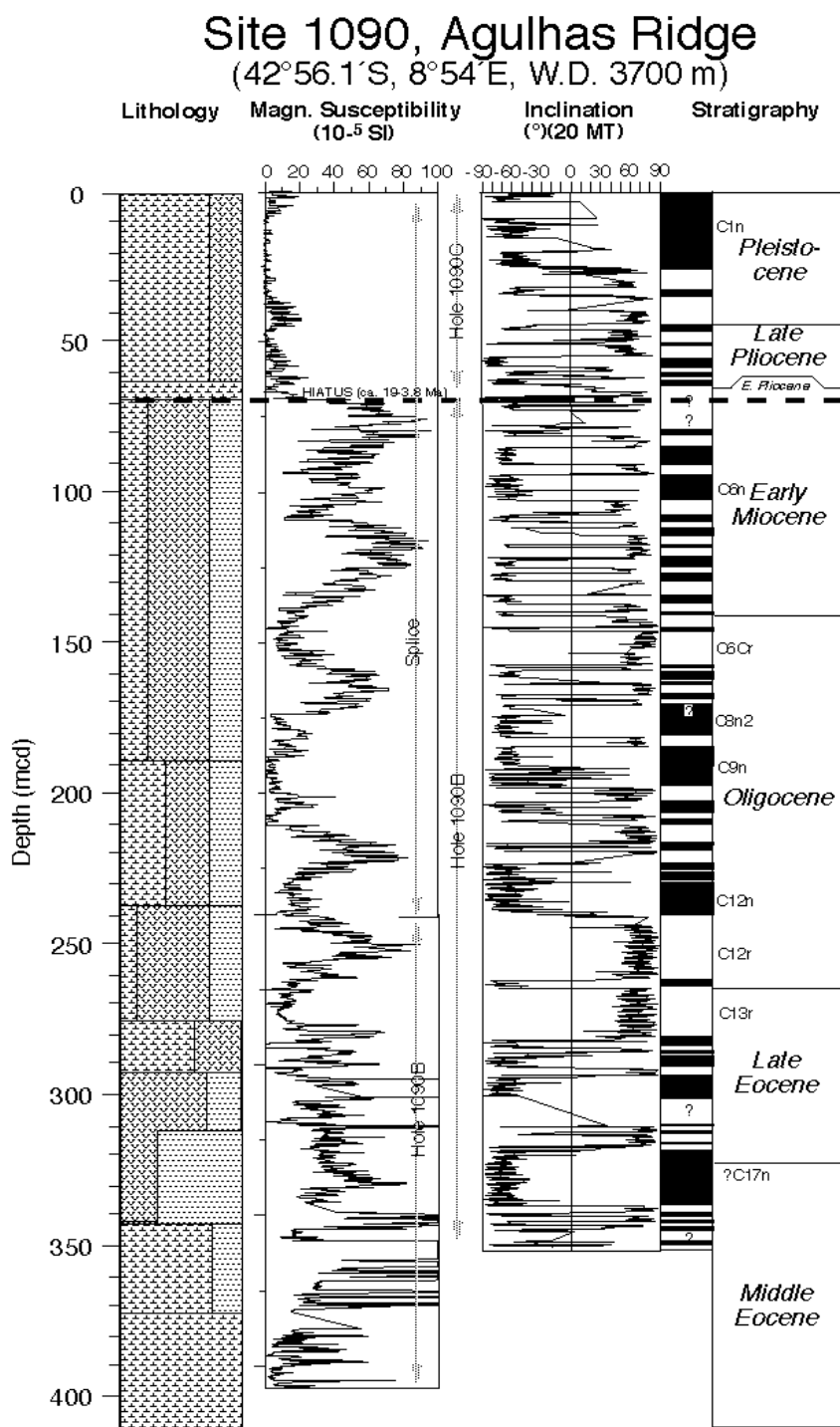

Figure 2: Lithology, magnetic susceptibility, inclination, and stratigraphy of Site 1090. A long hiatus (ca. 19 to 3.8 Ma) at ~70 m separates early Pliocene from early Miocene sediments.

mat material. The mats are remarkably similar to the vast Neogene laminated diatom mat deposits of the eastern equatorial Pacific Ocean (Kemp & Baldauf, 1993). Diatom mats are common in southern sites especially at the transitions to and from interglacial stages, resulting in expanded sections of glacial terminations. For example, the transition from MIS12 to MIS11 (Termination V) in Site 1093 is represented by a thick diatom mat that occurs over an 8-m interval. These mats can be thought of as “paleosediment traps” that preserve individual flux events, thereby providing the potential for generating paleoclimatic signals for certain intervals at a resolution that rivals that of ice cores.

Early Low-Temperature Porcellanite Formation

Four porcellanite horizons were recovered at Site 1094 between 68 and 164 mbsf, which form discrete layers that can be traced laterally as high-amplitude reflectors in Parasound seismograms. These porcellanite layers are intriguing because they were formed rather recently; for example, the

youngest porcellanite is found in sediments belonging to MIS 11 (~400 kyrs; Bohrmann et al., 1994). An anomalously low temperature gradient (~7°C/km) was measured at Site 1094, indicating that the porcellanites formed under low (near bottom-water) temperatures. Geochemical analyses of interstitial water and solid phase samples taken from near these porcellanite beds will be important for studying this case of early, low-temperature silica diagenesis.

Summary

Leg 177 marked the return of the *JOIDES Resolution* to the Southern Ocean after more than a decade, and the successful recovery of a superb suite of cores has significantly improved the latitudinal and bathymetric coverage of drilled-ocean sites in the high-latitude Southern Hemisphere. These cores will be used as the raw material for investigating the role of the Southern Ocean in millennial-scale climate variability, glacial/interglacial

Continued on page 21

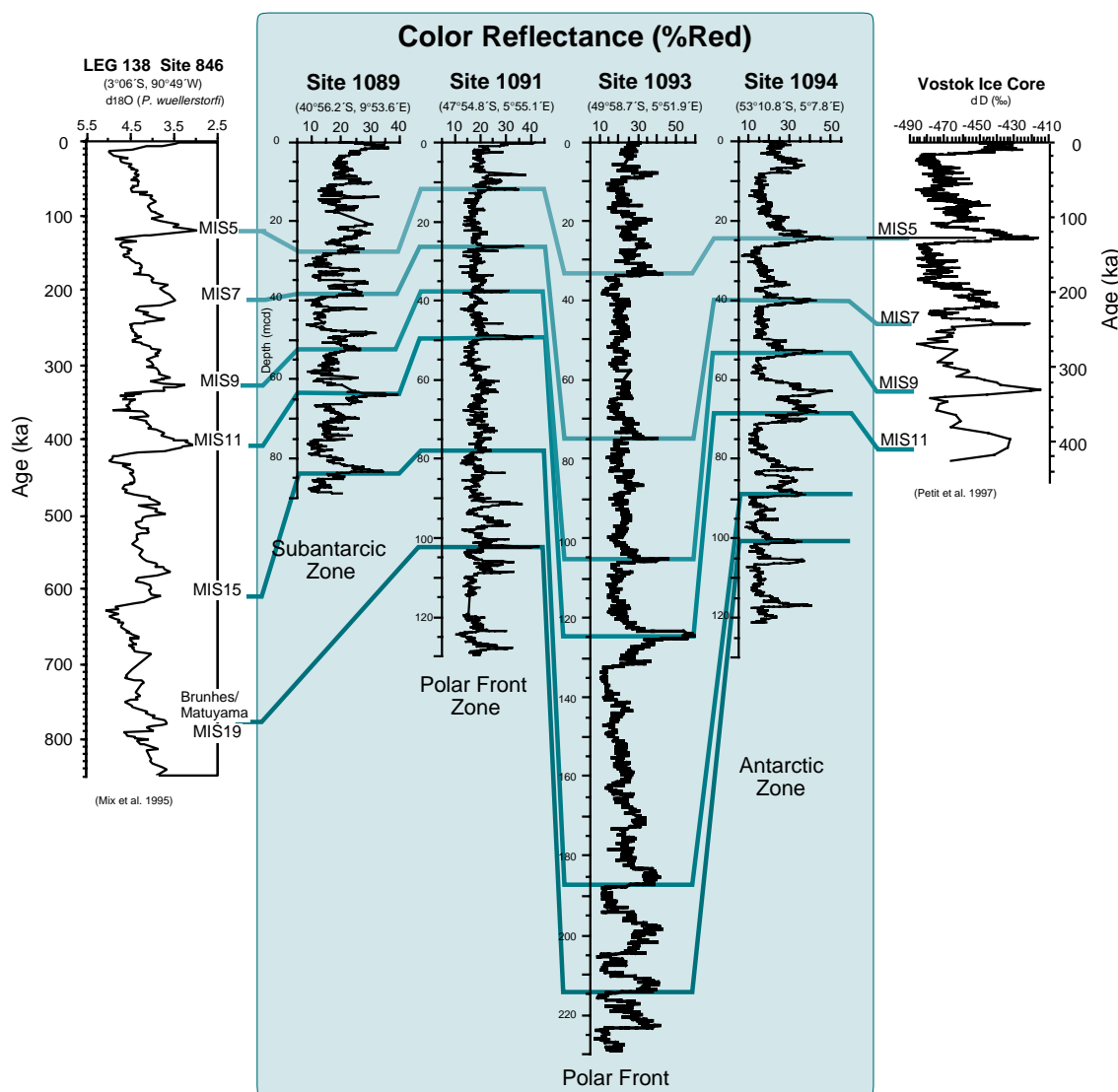

Figure 3: Correlation of percent red reflectance (650-750 nm) among Leg 177 Sites 1089, 1091, 1093 and 1094 along a north-south transect across the ACC. Peaks in color reflectance, reflecting increased carbonate content, have been correlated to the transitions between marine isotope stages of the late Pleistocene as expressed in the oxygen isotope record of Site 846 (Mix et al., 1995). Also shown is the deuterium isotopic record of the Vostok Ice Core for the last four climatic cycles (Petit et al., 1997).

Antarctic Glacial History and Sea-Level Change — Leg 178 Samples Antarctic Peninsula Margin Sediments

*Peter Barker, Angelo Camerlenghi, Gary Acton
and the Leg 178 Scientific Party*

The Antarctic Ice Sheet is a key feature of the global climate engine today, and has been so for most of its 35 Myr or longer history. It influences global circulation (mainly through bottom water production), eustatic sea-level change, biological production and albedo. And yet the details of that history are poorly known, despite two decades of measurement and interpretation of low-latitude ice-volume proxies. The most effective of those proxy measurements, oxygen isotopes and sea-level change, are ambiguous, and disagree.

Recently, a way out of this impasse has emerged, that is technically difficult but much

more direct. It involves sampling and dating sediments transported beneath the grounded ice sheet and deposited seaward of the grounding line around the Antarctic margin. We now appreciate that the ice sheet “drains” mainly by rapid flow in ice streams that slide on a shearing bed of diamict. Over the life of the ice sheet, those glacially-transported sediments have formed progradational wedges on the outer continental shelf. They, and their derived sediments redeposited in drifts on the upper continental rise, should therefore contain a record of ice sheet advance to the continental shelf edge. The prograded wedge is essentially unsorted,

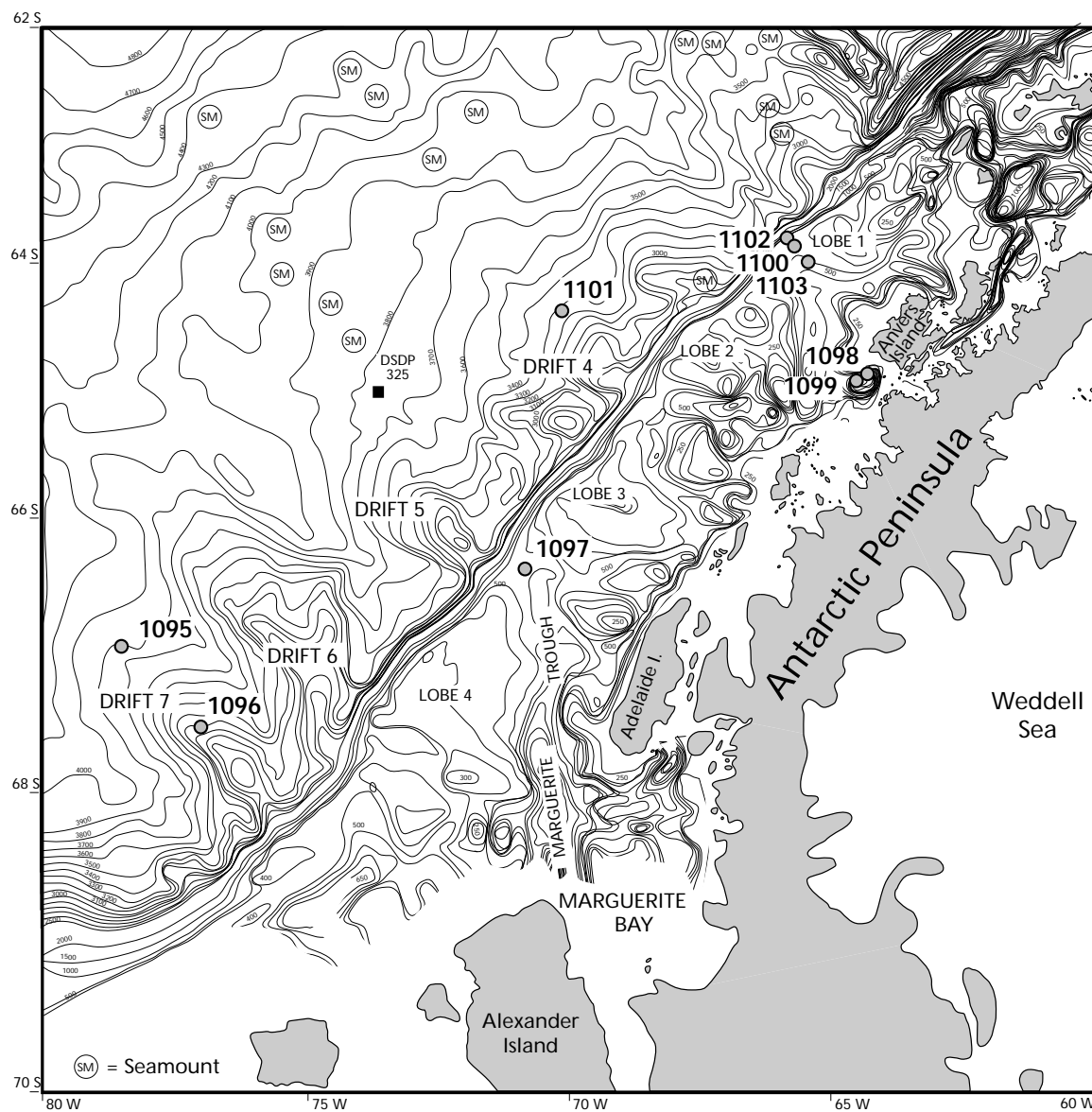

Figure 1: Leg 178 site locations: 1095, 1096 and 1101 are on upper continental rise sediment drifts; 1100, 1102 and 1103 form a shelf transect though a lobate prograding wedge and 1097 is between lobes where access to the deeper section is easier. Sites 1098 and 1099 sample a high-resolution Holocene section in an inner shelf basin.

making it difficult to recover, and the topsets are prone to subsequent erosion. The drifts have formed by more continuous deposition of sorted silty clays that are easier to recover but less direct, needing clues from the wedge to aid interpretation. The two depositional environments are complementary. Additional useful features of the Antarctic margin are the deep basins eroded on the inner continental shelf during glacial maxima, which preserve an expanded Holocene record of climate change.

By drilling at several places around the Antarctic margin, and combining the results using numerical models of ice sheet behavior, an ice sheet history can be derived (e.g., Barker et al, in review). Why then was the Antarctic Peninsula margin drilled first, of a suite of coordinated proposals? The Antarctic Peninsula ice sheet has always been small, and was initiated well after the East Antarctic Ice Sheet. However, it has been an excellent recorder of events over the past 10 Myr, which saw a change from southern to northern hemisphere drive for sea-level change, and included the “warm” early Pliocene which was proposed as having seen an almost completely deglaciated Antarctica. Moreover, the prograded wedge and the sediment drifts are particularly well represented and well mapped at the Antarctic Peninsula margin, making Leg 178 an effective test of technique.

Leg 178 drilled at nine sites in all (Fig. 1); four

on the outer continental shelf glacial prograded wedge (Larter et al, 1997), three on sediment drifts on the continental rise (Rebesco et al, 1997), and two in Palmer Deep (Leventer et al, 1995), an isolated basin of the inner shelf.

The continental rise sediment drifts (Sites 1095, 1096 and 1101) provided virtually continuous cores, back to 10-11 Ma at Site 1095, 4.7 Ma at Site 1096 and 3.1 Ma at Site 1101. All sites showed a cyclicity in sedimentation that reflected the cyclic provision of glacial sediments to the uppermost continental slope. Interglacial sediments were partly biogenic, usually bioturbated and slowly deposited (IRD abundance was high). Glacial sediments were usually barren silty clays, non-bioturbated, laminated and rapidly deposited. The depositional environments at the sites were different, ranging from dominantly hemipelagic on the rise crest to dominantly turbiditic at the distal site. As a guide to drilling at other Antarctic margins, this mixed depositional environment was an advantage: few of the other drifts around Antarctica are apparently as isolated from distal turbidite deposition as Drift 7 (Site 1096), so it is reassuring to know that a signal of cyclic glacial loading of the upper slope is found also within even a dominantly turbiditic environment such as Site 1095.

Sedimentation rates were highest on the drift crest (18 to 8 cm/kyr at Site 1096) and lowest on the distal flank (11 - 5 cm/kyr at Site 1095) as expected. At all three sites the rates decreased through the Pliocene and into the Pleistocene. The high rates will permit detailed studies of cyclicity in deposition: several parameters show variability with a period similar to the Milankovitch cyclicity seen in lower latitudes (notably 40 kyr within the Pliocene), including turbidite abundance, bioturbation, color, magnetic susceptibility and density (cores and logs) and probably IRD. Clay mineralogy varies between glacial and interglacials and could become a useful additional proxy. We even recovered nanofossils and foraminifera through part of the Plio-Pleistocene (Fig. 2), an unexpected circumstance. It seems clear that the continental rise is sensitive to variations in the glacial state of the continent, and that these reflect the orbital variation in insolation. This cyclicity persisted through the early Pliocene, arguing against significant deglaciation. A downward change at Site 1095 that sees no cyclicity before about 9 Ma marks a change in the level or nature of glaciation on the shelf, if not its initiation.

Drilling on the continental shelf aimed to test the pre-existing depositional model, and to date major changes in wedge geometry (for com-

Figure 2: Variations in calcium carbonate, colour and magnetic susceptibility in the period 0.8 to 2 Ma at rise site 1101. Carbonate content is mainly *Neogloboquadrina pachyderma sinistral*.

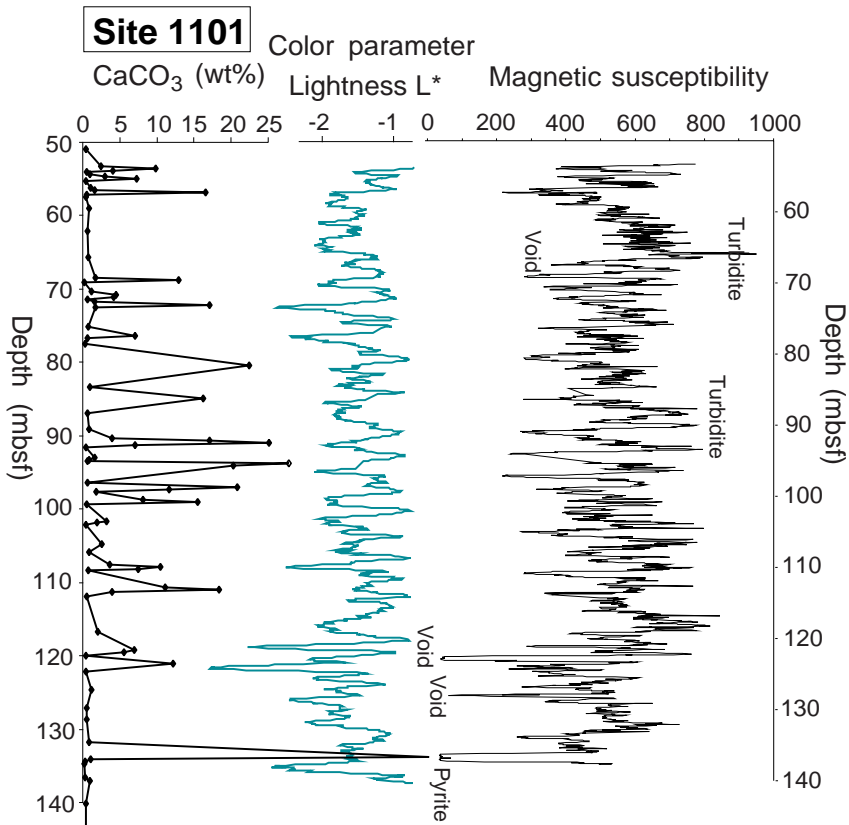

parison with changes in continental rise deposition). We drilled three sites on a dip transect of a depositional lobe (1102, 1100 and 1103, in landward order) and 1097 in an interlobe area farther south, where an older sequence was more accessible (Fig. 1). Drilling was severely hindered by swell, through restrictions on vessel heave, and recovery was made difficult (as expected) by the unsorted nature of unconsolidated subglacial and related diamict. We were limited to the basic RCB drilling technique, and recovery was poor until the fine-grained diamict matrix became sufficiently hard to support the inevitable large clasts. Recovery then improved (for example, to an average 34% below 250 m at Site 1103).

The glacial nature of the youngest sequence group S1, identified from seismic reflection was amply confirmed, and much of it could be given a Pleistocene or latest Pliocene age, but recovery was poor everywhere (the outermost shelf in particular). The most information on S1 is likely to come from the broad suite of logs obtained at Site 1103. Sequence group S2 was sampled only at Site 1097, where it is thin: its older part is early Pliocene in age. Sequence group S3, whose age and origin were in doubt before drilling, was sampled at Sites 1097 and 1103. S3 is continuous and similar in seismic expression along the West Antarctic margin to at least 105°W, and lacks the focus into depositional lobes of the overlying S2 and S1. It was clearly established as essentially glacial, though probably reflecting a greater range of environments than S2 and S1, from subglacial to glacial marine (Fig. 3), and probably a lesser level of glaciation. The conformity of its top with the base of S2, deduced from seismic profiles in the region of Site 1097, was confirmed by the age range for the boundary (4.5 - 4.6 Ma) established by drilling. Seismic data suggest that the part of S3 sampled at Site 1103 is older than at Site 1097. The inferred depositional environment of S3 at Site 1097 near the paleo-shelf edge, though lower-energy, was more open marine than at Site 1103. It is uncertain if this reflects a time change in climate or in depositional environment. Dating of the lower part of S3 is uncertain, but should be improved by shore-lab studies. It seems unlikely that the recovered sediments range back to 9 Ma, the time of a change in shelf environment inferred at Site 1095 on the rise. Overall, shelf drilling showed low recovery, and did not sample the conformal S2/S1 boundary as planned, but Leg 178 demonstrated that changes in wedge geometry can be sampled and dated effectively, provided that diamicts are consolidated and only low-resolution dating is required.

Preliminary results of **Palmer Deep** drilling accorded with expectations based on piston cores. A high-resolution record was continuously cored at both sites. Basin I, narrower and with thinner sediments, is less affected by turbiditic sedimentation than Basin III. The 45 m-thick sediment fill of Basin I (Site 1098) contains mainly laminated and massive muddy diatom ooze, with laminae probably reflecting changes in surface productivity. In Basin III (Site 1099) the alternation of laminated and massive muddy diatom oozes is interrupted more frequently by turbidites. A highly reflective lower seismic unit is an alternation of thin turbidites and laminated diatom ooze, with a strong impedance contrast with the upper semi-transparent unit. The downhole changes of diatom and fora-

Figure 3: The range of diamict encountered within the glacial sequence group S3 at Site 1097, including massive, stratified and graded diamict and mud, considered to represent an alternation of subglacial, glacial marine and open marine shelf environments.

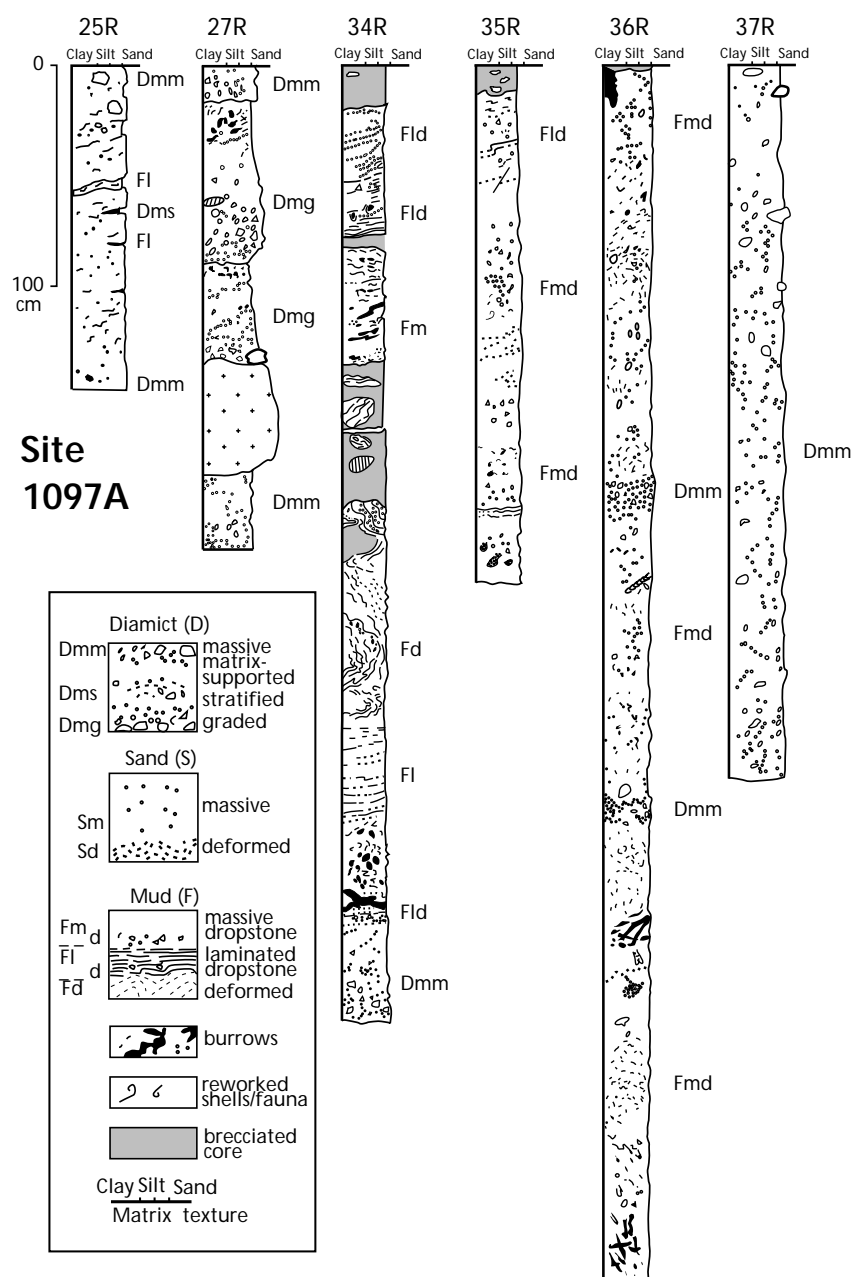

minifera assemblages indicating more restricted oceanographic conditions at the base of Basin I and in the lower part of Hole 1099B suggest that the two recovered sections underwent a similar evolution and may therefore be approximately coeval.

Shipboard analysis of Palmer Deep cores was limited, with sampling mainly post-cruise. The only high-resolution shipboard study (of pore water composition) revealed anomalous and still puzzling chemical gradients. Despite the inferred rapid but steady accumulation of sediment, pore waters in the upper 20 m at Site 1098 show a homogeneity that suggests almost complete mixing. The explanation will probably come from post-cruise studies of relationships between pelagic settling of organic-rich material, turbiditic sedimentation and bioturbation.

Several additional opportunities offered by Leg 178 drilling are being taken up by the shipboard party. The continuous, high-resolution, partly terrigenous record of the continental rise drift sites, and the high southern latitude, provide excellent paleomagnetic data presenting opportunities for studies of field paleo-intensity and rock magnetism, and detailed examination of particular reversals. The Palmer Deep sediments are also expected to provide high-resolution paleo-intensity data. The existence of a detailed high-latitude magnetostratigraphy, and location of the rise sites in a low-energy environment securely within the Antarctic water masses, provide opportunities also to check and refine high-latitude biostratigraphy. These will be further enhanced if an orbital chronology can be established.

Pore water geochemistry is of interest at several sites, notably Palmer Deep where it seems capable of informing the wide range of high-resolution investigations currently planned. The logging effort, though curtailed by hole conditions in places, generated a wide range of physical properties and log data from a cluster of generically-related environments that will repay closer study. This leg has seen the first ever FMS examination of subglacial tills, at Site 1103, and the comparison between high-quality core magnetostratigraphy and the GHMT record at Site 1095 should also be productive. VSP and sonic logs will aid correlation between the hole and the seismic record, and allow the results of drilling to feed back into the exceptionally large regional seismic reflection data set.

An additional opportunity, not considered within proposals or discussed in the Leg Prospectus, is the possibility of detecting at the rise sites the late Pliocene Eltanin asteroid impact. The sites

lay 1300 km distant from the likely impact area, and the rise drifts, being at their crest only perhaps three quarters the water depth of the direct path, seemed areas where a sedimentological event might be detectable, in addition to the likely geochemical and paleontological anomalies which by themselves would be difficult to find. At present, until stratigraphic control has improved, the impact is not clearly identified within the sediments, but each rise site shows a single anomalous depositional or erosional event, which it is tempting to associate with it.

Leg 178 Shipboard Scientific Party:

Peter Barker, Co-Chief Scientist, British Antarctic Survey, Cambridge, United Kingdom; Angelo Camerlenghi, Co-Chief Scientist, Osservatorio Geofisico Sperimentale, Trieste, Italy; Gary Acton, Staff Scientist, ODP, Texas A&M University, College Station, Texas; Stephanie Brachfeld, Ellen Cowan, Jim Daniels, Eugene Domack, Carlota Escutia, Andrew Evans, Nick Eyles, Yohan Guyodo, Marina Iorio, Masao Iwai, Frank Kyte, Christine Lauer, Andres Maldonado, Tobias Moerz, Lisa Osterman, Carol Pudsey, Jeff Schuffert, Charlotte Sjunneskog, Kate Vigar, Amy Weinheimer, Trevor Williams, Diane Winter and Thomas Wolf-Welling.

REFERENCES

- Barker, P.F., Barrett, P.J., Camerlenghi A., Cooper A.K., Davey, F.J., Domack E.W., Escutia C., Kristoffersen, Y. and O'Brien, P.E. (in review). Antarctic Ice Sheet history from continental margin sediments: the ANTOSTRAT approach. *Terra Antartica*, submitted.
- Larter, R.D., Rebesco, M., Vanneste, L.E., Gamboa, P.A.P., and Barker, P.F., 1997. Cenozoic tectonic, sedimentary and glacial history of the continental shelf west of Graham Land, Antarctic Peninsula. *In: Barker, P. F. And Cooper, A. K. (Eds), Geology and Seismic Stratigraphy of the Antarctic Margin, Part 2, AGU Antarctic Research Series, 71, 1-27.*
- Leventer, A., Domack, E.W., Ishman, E., Brachfeld, S., McClennen, C.E., and Manley, P., 1996. Productivity cycles of 200-300 years in the Antarctic Peninsula region: understanding linkages among the sun, atmosphere, oceans, sea ice, and biota. *Geol. Soc. Amer. Bull.*, 108, 1626-44.
- Rebesco, M., Larter, R. D., Barker, P. F., Camerlenghi, A. and Vanneste, L. E., 1997. The history of sedimentation on the continental rise west of the Antarctic Peninsula. *In: Barker, P. F. And Cooper, A. K. (Eds), Geology and Seismic Stratigraphy of the Antarctic Margin, II, AGU Antarctic Research Series, 29-50.* ❖

A Long Gabbro Section in the Ocean Crust: Results of Leg 176 Drilling, Southwest Indian Ridge

by James H. Natland, Henry J.B. Dick, and the
Leg 176 Shipboard Scientific Party

A long-standing objective of the Ocean Drilling Program has been deep penetration of the ocean crust, far into the plutonic lower crust and into the upper mantle. One way to sample the lower ocean crust is to find a location where basalts and dikes, which are difficult to drill, have been removed by tectonic processes or erosion. The high transverse ridges of major fracture zones in the Atlantic and Indian Oceans have long been known as places where gabbroic and serpentinized ultramafic rocks are consistently exposed to the dredge, and which therefore potentially afford the drill a short path to the crust-mantle transition. One such location is atop a flat wave-cut platform at Atlantis Bank (Fig. 1), the eastern transverse ridge on Atlantis II Fracture Zone, which was swath mapped in 1986 (Dick et al., 1991a) and then drilled in 1987. The drilled section, obtained in only 720 m of water at ODP Hole 735B during Leg 118 (Robinson et al., 1989) comprises just over 500 m of abyssal gabbro, and the hole, which was equipped with a re-entry cone atop a hard-rock base, was left open for future drilling.

During Leg 176 (Oct. - Dec. 1997) Hole 735B was extended to a total depth of 1508 m with a total recovery rate of cored rock of 86.6%. Unfortunately, a sudden and unexpected drill-string failure in high seas rendered the hole no longer open for further drilling. However, the long composite section obtained over two legs, together with the high recovery, makes this by far the greatest technical success of any hole ever drilled into the ocean crust. That the section consists entirely of plutonic rock makes it ideal for comparison to

ophiolites and layered intrusions, and to contribute to models of accretion of ocean crust at spreading ridges.

Lithostratigraphy and Structure

In outline, the gabbroic ocean crust drilled over two legs consists of five main masses of relatively primitive olivine gabbro and troctolite, each from 250-450 m thick, and each with its own internal chemical and petrological coherence (Fig. 2A). Each of these plutonic masses is composed of many smaller magma bodies, which separately probably represent small intrusive masses typically a meter or less in thickness, that penetrated either fairly cold rock, or more usually, crystal mushes. During Leg 176, 457 such small igneous bodies, which we term "intervals" were described, adding to the 495 described during Leg 118 (Dick et al., 1991b). A running average of the proportion of different igneous lithologies represented by these intervals and taken 20 intervals at a time (Fig. 2B) shows that the upper, middle, and lower 500 m portions of Hole 735B are each distinct, and in no way replicate each other. The numerous small crosscutting intervals of olivine gabbro and troctolite within the larger plutonic masses may represent feeder channels for melts which migrated through crystal mushes toward the sea floor. Each of the larger, composite plutonic bodies nevertheless has more fractionated gabbros toward its top, and the most primitive and magnesian rocks, whether olivine gabbro or spinel-bearing troctolite, toward its base. The occurrence of multiple composite intrusions, with large-scale repetitions of magmatic crystallization sequences,

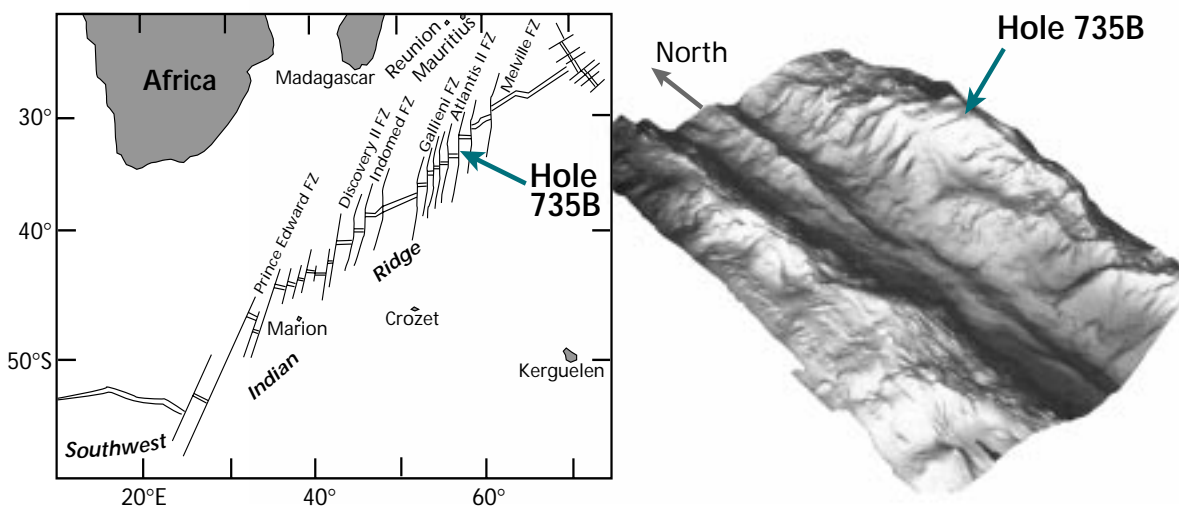

Figure 1: Location of Hole 735B on the Southwest Indian Ridge, and an oblique shaded-relief image of a portion of the Atlantis II Fracture Zone transform valley, showing Atlantis Bank, where Hole 735B was drilled. The relief image, from the frontispiece of Proc. ODP, 118, Scientific Results (Von Herzen, 1991), is based on a SeaBeam survey carried out in 1986 (Dick et al., 1991b), and represents an area of about 4000 km². Hole 735B is in 720 m of water, and the floor of the transform valley is about 6000 m deep.

indicates that this portion of the Southwest Indian Ridge was not supplied by a steady-state magma source. Each pluton probably represents a major pulse of magma, albeit injected one small bit at a time, but which *in toto* added significantly to the thickness of this block of ocean crust.

The entire section is crossed by numerous small bodies of oxide-bearing and oxide-rich gabbro, gabbronorite, and olivine gabbro, each typically only a few to a few tens of centimeters thick. We identified more than 600 such small bodies of differentiated rock by routine measurement of magnetic susceptibility, which is sensitive to the quantity of coarse-grained magnetite, using the multisensor track (MST), and more than 250 felsic veins, these usually associated with oxide gabbros (Fig. 3). The compositions of most of the gabbros of Hole 735B indicate that they are deficient in the very geochemical constituents which are so concentrated in the oxide gabbros and felsic veins, suggesting that iron-rich liquids were expelled from their crystalline matrix by the interactive processes of crystallization and compaction, with perhaps an assist from the stresses that formed the shear zones.

We thus imagine that there was a series of nested plutons, each consisting of dozens to hundreds of much smaller crystallizing intervals of troctolite, olivine gabbro and gabbronorite. The entire mass was above the basalt solidus; thus, each of these smaller masses had the potential to contain some intergranular melt, which could reach an extremely differentiated, iron-rich or even granitic

composition whenever the temperature dropped low enough, as clearly happened even near the base of the section. Such melts would have tended to concentrate ahead of solidification fronts within each small mass (Marsh, 1995), but also to migrate upward by buoyancy forces through the entire collection of plutonic material, as long as there was some interconnected porosity structure. Compaction and perhaps deformation led to extremely efficient expulsion of the strongly differentiated melts from most of the material, and to their concentration along numerous small gashes, fractures, or other porosity structure that they encountered. How that flow was stopped to allow the melts to collect and concentrate is not yet resolved, although there is a strong tendency for oxide gabbros to be associated, but not always coincident, with shear zones having fairly strong crystal-plastic deformation. There is also a significant concentration of oxide gabbros in the upper third of the hole (Fig. 2B). The general relationships of the oxide-rich seams to the olivine gabbros, however, indicate that not even the initial plutonic mass emplaced in this section was completely crystalline before the last one was injected. The whole body of rock retained some fraction of melt, and some interconnected porosity structure, throughout the entire history of magma supply from the mantle. Highly differentiated residual melts were not trapped where they formed, but they were squeezed from their host rocks, to stream away in a channelized/porous-flow network to other places where they

Figure 2: Chemical- and lithostratigraphic summary of Hole 735B. Data are from Robinson et al. (1989), Dick et al. (in press), and J. Hertogen (unpublished).
A. Mg# versus depth ($Mg\# = Mg / ([Mg + Fe^{2+}])$, assuming that $Fe^{2+} / [Fe^{2+} + Fe^{3+}] = 0.86$). Dashed lines at bases of major breaks in compositional trends define five principal plutonic masses within the drilled section, each becoming more differentiated (proportionally iron-rich) upward, as indicated by the diagonal arrows. All other samples represent narrow, cross-cutting facies each typically 5-15 cm thick.
B. Simplified summary of the lithostratigraphy giving the main lithologic units defined during Legs 118 and 176, proportions (%) of intervals of principal lithofacies constructed using a rolling average at 20-m intervals, and structure. (SZ = shear zone, F = fault.) Horizontal lines are drawn across the lithofacies summary at 500-m intervals.

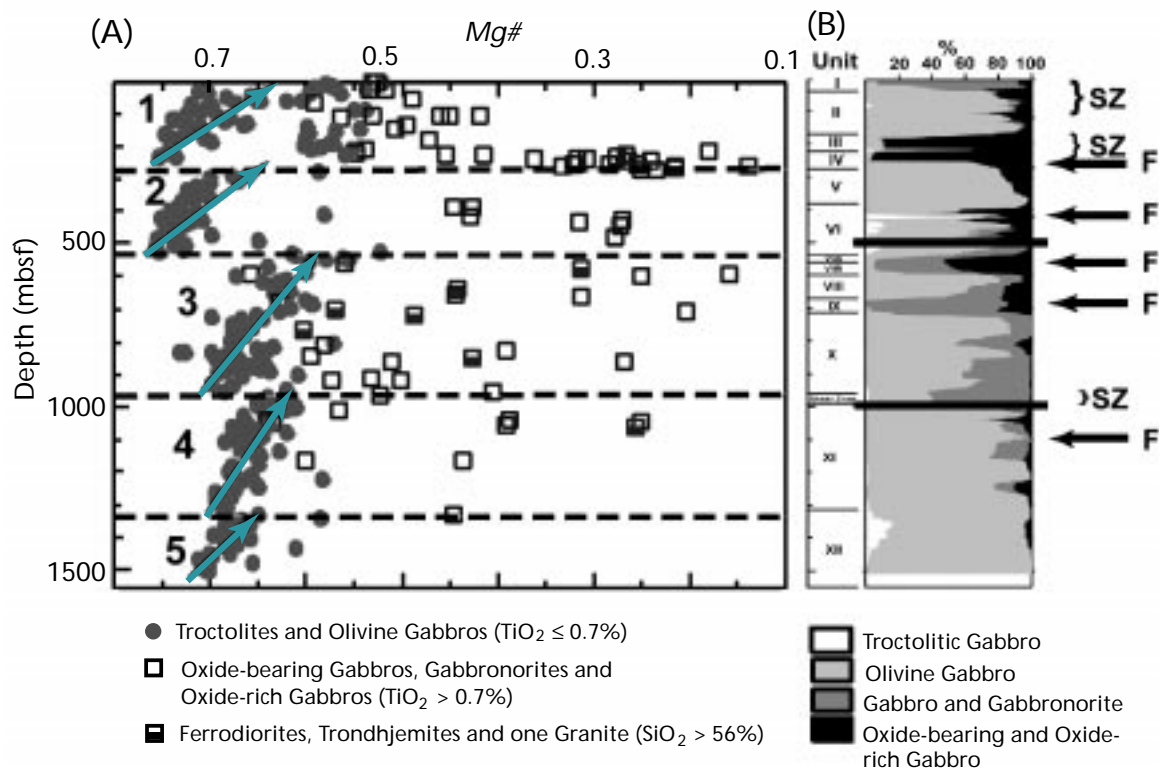

coalesced and precipitated large quantities of oxide minerals.

The structural observations indicate that the processes that controlled crustal accretion at this very slowly spreading ridge were strongly influenced by localized deformation under conditions ranging from magmatic to low-temperature cataclastic. The rocks began deforming at the magmatic stage, and this continued through most stages of subsolidus recrystallization, metamorphism, and alteration. About 30% of the rocks drilled in the upper 500 m of the hole are strongly deformed, such that many rocks have gneissic, porphyroclastic, and even mylonitic textures. The deformation diminishes downward to less than 5% in the lower 500 m of the hole. The pattern of deformation decreasing downward is the opposite to that observed in some ophiolites, and contrasts particularly to Oman where strong crystal-plastic fabrics are not developed at all.

Metamorphism

The metamorphism and alteration in the rocks of Hole 735B occurred in two stages. The first produced a high-temperature sequence from granulite to amphibolite facies in a dynamic environment, and this type of alteration is concentrated towards the top of the hole with only minor greenschist mineralization. This alteration occurred as the rocks were cooling from the magmatic stage and through the subsolidus to the beginning of uplift from beneath the rift valley. Faults represented by zones of both high- and low-angle shear penetrated a crystal mush deep beneath the axial rift. This deformation and crystallization may have started even before aggregation of iron-rich liquids to form oxide gabbros.

The second stage involved alteration at lower temperatures. It was related to different sets of fractures, and likely represents processes which occurred after the stage of major uplift of the sequence to the summit of the transverse ridge, up to the present day. It is local rather than pervasive in the core, being most prevalent below 500 mbsf, and it is represented by abundant late smectite, carbonate, and zeolite-prehnite veins, locally with iron oxyhydroxides. Near the base of the hole, there are abundant smectite-lined fractures, these associated with sulfides, indicating formation under non-oxidative, low-temperature conditions.

Magnetic and Physical Properties

Rock magnetic measurements have resulted in the satisfying picture that the entire body of rock cored during Legs 118 and 176 has a consistent average stable inclination of 71°, and no observable downhole variation. The rocks were tilted by about

20° but have a very stable remanent magnetization and often very sharp blocking temperatures, suggesting relatively rapid acquisition of thermoremanence during cooling. This cooling took place while the rocks were beneath the rift valley, and shortly after they crystallized. They thus constitute an ideal source for marine magnetic anomalies, and a gabbroic layer as thick as our drilled section is nearly sufficient to account for the marine magnetic anomaly near Hole 735B on Atlantis Bank.

Variations in rock density of minicores are slight, with oxide gabbros attaining densities of 3.2 gm/cm³, compared with an average of all lithologies of 2.98 gm/cm³. Two shallow reflectors beneath the base of the hole drilled during Leg 118 were detected by means of a vertical-seismic profile at the end of that leg (Swift et al., 1991). The con-

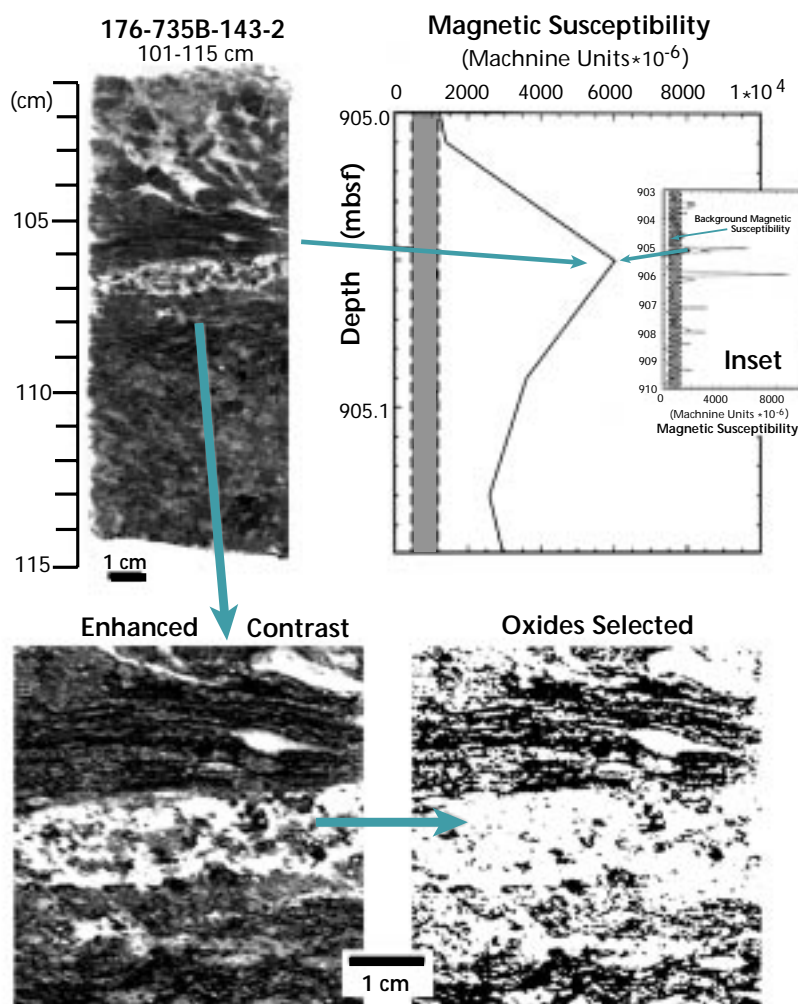

Figure 3: Scanned image of an example of the association of a felsic vein (white) with oxide-rich gabbro at about 905 mbsf in Hole 735B (upper left), linked to Multi-sensor Track (MST) measurements of magnetic susceptibility at 4-cm intervals on the unsplit core (upper right). The magnetic susceptibility inset shows the individual susceptibility peak among several others in a 7-m section of core. Over 600 similar peaks were measured altogether in the 1004-m of core drilled during Leg 176, almost all of them indicating very local high proportions of magmatic oxides in the core. The lower panels focus on the nearly horizontal felsic vein, and show, by means of successive enhanced-contrast selection of the dark oxide minerals, the association of coarse ilmenite and magnetite with the vein, and that rock near the vein is strongly foliated.

tinued drilling shows that these are not the result of the intrinsic physical properties of the gabbros themselves, but instead, they correspond to the presence of faults and fractures, for which we found evidence in the cores, in intervals where the percentage of recovery was reduced. Downhole logs obtained at the end of Leg 176 indicate two closely spaced faults near the uppermost reflector at 560 mbsf, and show for this interval reduced formation velocity, density, and resistivity, as well as elevated porosity.

Comparisons to Ophiolites and Layered Intrusions

In a number of respects, Hole 735B is unlike any of the well-studied ophiolites, such as Troodos, Bay of Islands, or Oman. All of these have the most differentiated rocks concentrated at the tops of their gabbroic sections, near the bases of sheeted dikes (e.g., Pallister & Hopson, 1983). None of these have the hundreds of oxide-rich seams distributed up and down the sequence, seen in the cores of Hole 735B. These ophiolites are also more, rather than less, deformed with depth, yet they have few or no rocks with gneissic, porphyroclastic, or mylonitic textures. Nevertheless, since the initial drilling of Hole 735B during Leg 118, these types of deformational features have been found at the Lizard ophiolite, on the Cornish coast of England (Hopkinson & Roberts, 1995), and in the Ligurian Alps (Caby, 1995). However, systematic relationships through a long sequence of gabbros have not yet been established at any of these ophiolites.

Still less does this sequence of rocks resemble a layered igneous intrusion. Distinct modal layering occurs in only one short interval of the core (818-823 mbsf), and it is not yet certain that it was produced by gravitational sorting of crystals. Instead, the great bulk of the cored rocks consists of hundreds of mineralogically or texturally distinct lithologic intervals, with contacts that are usually gradational or sutured, and steeply inclined to vertical. Most crystallization thus occurred in small dike-like bodies rather than a ponded body of magma. Advanced differentiation occurred in channels, fractures, and intergranular porosity networks after intergranular melts were squeezed from the more primitive gabbros and while they migrated buoyantly upward toward cooler reaches of the crust in the deforming, partly molten crystal mush. However, complex patterns of enhanced and reduced permeability, including localized grain-size reduction in zones of more intense deformation, influenced the pathways of these migrating melts, and dictated where they finally were able to concentrate. Upward migration to a single melt lens of the

type visualized for fast-spreading ridges did not occur; it was at least partially thwarted by the complexity of the overlying multiply-intrusive stratigraphy, and by ongoing deformation.

Conclusions

Hole 735B demonstrates the importance of synkinematic igneous differentiation (Dick et al., 1991a), also termed differentiation by deformation (Bowen, 1920), in the ocean crust. It allows a comprehensive assessment of this process wherein shallow gabbros, occurring in the form of small, nested plutons, were enriched in late iron-rich melt derived from a collection of plutons by means of compaction (or filter-pressing) and tectonic processes, rather than simple gravitationally-driven crystallization differentiation. High-temperature metamorphic and deformational processes which began well before crystallization was completed, continued into the subsolidus, followed by lower-temperature metamorphism and alteration, but at this stage with little attendant deformation of the uplifting mass of plutonic rocks. This was the point when the stable thermoremanence was acquired, accounting for the persistence of magnetic anomalies across Atlantis Bank, and perhaps explaining why there are magnetic anomalies at all along slowly-spreading ridges. Hole 735B allows us to assess these complexly interactive processes in a known tectonic setting, at a ridge of established rate spreading rate and topography. It is, and it is likely to remain, the standard section for a slowly-spreading ridge.

The Leg 176 Scientific Party

Henry J.B. Dick, Co-Chief Scientist, Woods Hole Oceanographic Institution, MA, USA; James H. Natland, Co-Chief Scientist, University of Miami, FL, USA; D. Jay Miller, Staff Scientist, ODP, Texas A&M University, College Station, TX, USA; Jeffrey C. Alt, Wolfgang Bach, Daniel Bideau, Jeffrey S. Gee, Sarah Haggas, Jan G.H. Hertogen, Gregory Hirth, Paul Martin Holm, Benoit Isledelfonse, Gerardo J. Iturrino, Barbara E. John, Deborah S. Kelley, Eiichi Kikawa, Andrew Kingdon, Petrus J. LeRoux, Jinichiro Maeda, Peter S. Meyer, H. Richard Naslund, Yao-Ling Niu, Paul T. Robinson, Jonathan Snow, Ralph A. Stephen, Patrick W. Trimby, Horst-Ulrich Wörm, and Aaron Yoshinobu.

REFERENCES

- Bowen, N.L., 1920. Differentiation by deformation. *Proc. Nat'l. Acad. Sci.* 6:159-162.
Caby, R., 1995. Plastic deformation of gabbros in a slow-

Continued on page 30

Leg 179: Hole 1105A and NERO Hole 1107A

by **John F. Casey, Jay Miller**
and the **Leg 179 Shipboard Scientific Party**

ODP Leg 179 involved two primary objectives aimed at longstanding gaps in our understanding of the nature of the solid earth. First, new hammer drill-in casing technology was tested on the Atlantis Bank, Southwest Indian Ridge (Fig. 1). This system is likely to enable bare rock spud-ins on low to moderate slopes, and the establishment of stable upper holes in hard rock environments. This should eventually lead to deeper drilling and higher recovery from the ocean crust. The second goal was to prepare a site on the Ninetyeast Ridge (Fig. 1) where a long-term geophysical ocean bottom observatory (NERO) will be established as part of the International Ocean Network (ION). A series of ancillary objectives were also planned for the Leg.

Both of the primary objectives were accomplished during Leg 179. Initial tests of the hammer drill, although incomplete as envisioned in the Scientific Prospectus, yielded data that will allow a detailed evaluation of the technology and will result in modifications to various components of the system (Pettigrew & Holloway, this issue). The NERO hole was drilled to nearly 500 m depth and cased to basement, and left with a reentry cone to allow installation and maintenance of a downhole observatory in the future. Extensive seismic-while-drilling (SWD) data were collected at both the hammer drill test sites and at NERO, using two USGS OBSs. These experiments were conducted during both RCB and hammer drilling to attempt analysis of both types of signals. The SWD data, together with accelerometer data from the drillstring (Goldberg et al., this issue), await shorebased processing in order to evaluate the feasibility of this tool during drilling operations.

Unfortunately, as a result of an extended delay in port due to ship repairs, loss of equipment in shipment, and long transit times (Cape Town - Atlantis Bank-Ninetyeast Ridge-Darwin, Australia), 17 of the 26 operational days scheduled for primary and ancillary objectives in the prospectus were lost. Although the highest priority for ancillary experiments was given to a two-ship offset experiment at NERO in coordination with the German research vessel *Sonne*, regrettably time constraints prevented its completion. Other planned experiments that could not be completed include a conventional vertical seismic profile (VSP) experiment, a test deployment of a borehole seismometer, and logging and coring of the NERO hole.

Site 1105, Atlantis Bank

Because of delays in the arrival of a resupply ship carrying components of the hammer-drill system, Hole 1105A was drilled during the wait. The hole was located ~1.3 km east-northeast of Hole 735B (Dick et al., 1991) on the Atlantis Bank along the eastern transverse ridge of the Atlantis II Transform (latitude 32°43.13'S, longitude 57°16.65'E). The site is in a near ridge-axial trend with respect to Hole 735B, but more distal from the north-south trending Atlantis II Transform that lies to the west (Natland et al., this issue). The site was chosen to avoid a duplication of efforts directed toward the study of Hole 735B core, but at the same time, it was drilled close enough to Hole 735B to utilize it as a reference section to attempt lateral correlation of large-scale igneous units,

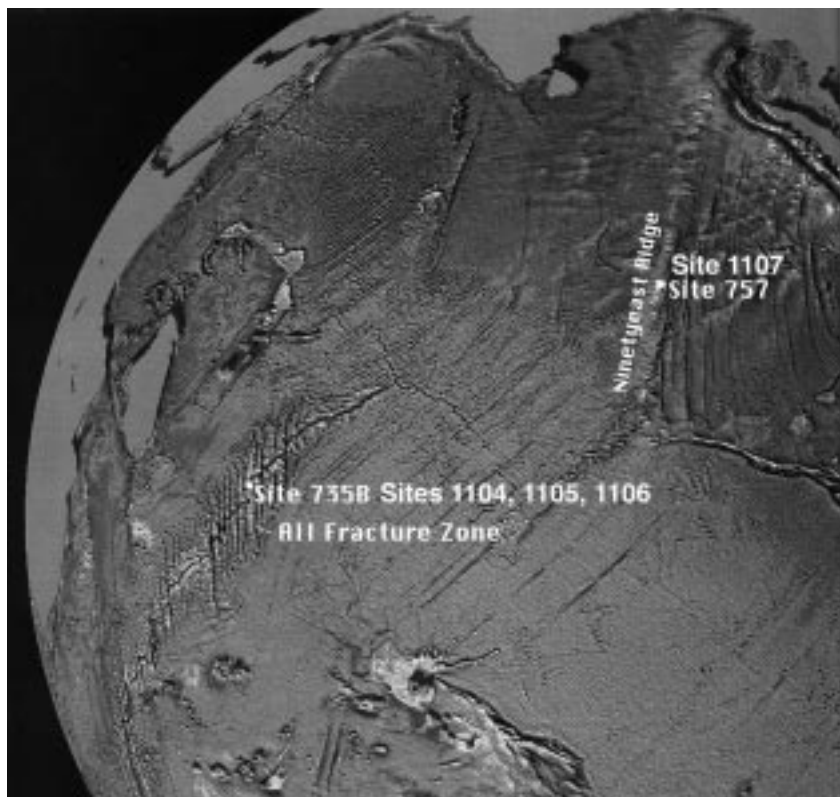

structural features, and geophysical data over the broader distance represented by the offset in holes. The offset direction was chosen to be approximately parallel to the former ridge axis (i.e., along an isochron) to enhance the chances of correlation at plutonic levels. In addition, the site was selected to help constrain the overall structure of the massif exposed on the Atlantis Bank. If successful, the cor-

Figure 1: Satellite altimetry map of the Indian Ocean showing Leg 179 Site locations near previously drilled ODP Hole 735B (Legs 118 and 176) on the Atlantis Bank, situated along the Atlantis II Transform and Site 757 (Leg 128).

relation attempts could yield a minimum measure of the dimensions of subaxial magma chambers or chamber systems, and help establish the extent of continuity of structures and processes along strike of the ridge axis at a very slow-spreading center. A full and highly successful logging program that was completed after the cessation of drilling Hole 1105A will aid in achieving the correlation.

Because time was too limited (6 days) to establish a hard rock guide base and to core to significant depths in the high sea state drilling conditions that were encountered, a highly unusual approach to spudding and initiating a bare rock hole was chosen to achieve the maximum scientific return. Hole 1105A was first drilled to a depth of 15 mbsf using a 14-3/4 in tricone bit followed by the emplacement of a free-fall funnel to stabilize the hole. The hole was then cored to a depth of 158 mbsf using a rotary core barrel and achieved 82.8% recovery. The cored interval measured 143 m and the recovered core included 118.43 m of gabbroic rock. Together with logging results, this recovery provides a rather complete coverage of the rock types and a comprehensive view of pseudostratigraphy in the gabbroic section cored. Shipboard results already indicate a high probability for a successful lateral correlation between Holes 735B and 1105A.

A wide variety of rock types including gabbro, oxide gabbro with up to 20-25 modal percent Fe-Ti oxides, olivine gabbro and scarcer troctolitic gabbro, gabbronorite, and felsic rocks such as trondhjemite were recovered. One hundred and forty-one rock intervals have been described within the core, defined on the basis of distinct changes in mode, modal proportions, grain size, and/or texture. Well-defined igneous layer contacts or structural boundaries to these intervals are preserved in many sections of the core. The highly layered nature of the gabbroic rocks documented within the core is supported by high-quality continuous FMS (Formation Micro Scanner) logs of the borehole, as well as other logs and downhole whole-core magnetic susceptibility measurements. On a broader scale the intervals have been grouped into four basic units, which from top to bottom consist of

- Unit 1: a gabbroic unit, 33.14 m in thickness, characterized by more primitive gabbroic rock types and by a scarcity of oxide gabbro;
- Unit 2: a gabbroic unit, 88.24 m in thickness characterized by high abundances of oxide gabbro and oxide-bearing gabbroic intervals interlayered with more primitive gabbroic rock types;
- Unit 3: a gabbroic unit, 14.22 m in thickness characterized by more primitive rock types and a lack of oxide gabbros, and finally;

- Unit 4: another gabbroic unit rich in oxide gabbro and oxide-bearing gabbro having a minimum thickness of 6.84 m. Rocks are crosscut by mm to dm sized veins of leucocratic gabbro, quartz diorite, trondhjemite, and irregular pegmatitic gabbro intrusions.

The structure of the core is complex with structural styles and intensities ranging from brittle to ductile. Most of the gabbroic samples cored possess igneous textures, but there are several parts of the core that display crystal-plastic fabrics. Coarser grained cm to dm thick ductile shear zones are present in the upper 90 m of core, whereas thicker zones of ductile deformation with weak to strong crystal-plastic fabrics become more prevalent at depths in excess of 90 mbsf. Intervals of penetrative ductile deformation in the lower portion of the core exceed 2 m in thickness locally. Zones of ductile deformation are commonly oxide rich, as are the contact regions between undeformed and ductily deformed rocks. Oxide-gabbro-rich zones tend to localize strain as many, but not all, of the ductile shear zones are rich in oxide minerals. Brittle fractures are generally filled with vein material such as actinolite, chlorite, calcite and smectite.

Preliminary analysis of the downhole geophysical measurements from core and logging measurements yield a wide variety of information. Magnetic data indicate that the core possesses a single coherent magnetic direction with an average inclination of $\sim 67^\circ$. This is compared with an inclination of -52° expected for the site. As in Hole 735B, these results indicate a consistently reversed polarity for the section and may indicate a significant block rotation of the massif similar in magnitude to rotations interpreted from Hole 735B (15° - 20°). The consistency of the magnetic inclination suggests that any relative rotations along ductile shear zone in the section must have occurred prior to cooling below the blocking temperature and are necessarily high temperature in nature. Magnetic susceptibility measurements clearly define zones of oxide gabbro and oxide-bearing gabbro documented in the core. Likewise it provides a direct downhole comparison for the FMS logs, which measure resistivity. Oxide-rich zones are conductive whereas oxide-free zones have high resistivity. Preliminary observations suggest that Unit 4 defined in Hole 735B (Dick et al., 1991) and Unit 2 in Hole 1105A, as well as underlying and overlying units, may be correlated based on lithologic and geophysical similarities. Confirmation of this correlation will be provided by detailed shore-based studies of the core.

The Ninetyeast Ridge Geophysical Observatory (NERO)

Seismic data from a World-Wide Standardized Seismograph Network (WWSSN) established in the early 1960s accelerated advances in seismology and were a great resource of new discoveries up to the 1970s. During the past ten years, our knowledge of the processes of the deep Earth has been greatly improved by the development of new generations of global monitoring networks in seismology, geodesy, and geomagnetism. While the quantity and quality of data have increased, this new information has revealed that there are large departures from lateral homogeneity at every level from the Earth's surface to its center. The intensive use of broadband data has provided remarkable seismic tomographic images of Earth's interior. These models are now routinely used in geodynamics for earthquake studies and to obtain the complex time histories of the inhomogeneous earthquake faulting related to tectonics.

The scientific community has recognized that global seismic observations will remain incomplete until instruments are deployed on the ocean floor. The

need for ocean bottom observatories for geodetic, magnetic, and seismic studies is driven by the same factor, the lack of observations in large tracts of the world ocean where neither continents nor islands are available to place observatories. The problem of extrapolating the magnetic field to the core-mantle boundary is greatly exacerbated by gaps in observation sites in the Indian Ocean and eastern Pacific Ocean. Images of the interior velocity heterogeneity, in turn related to thermal and chemical convection, are "aliased" by the lack of control from seismic stations in the Indian and Pacific Oceans

The installation of ocean bottom seismic stations, their maintenance, and the recovery of data on a timely and long-term basis represent a formidable technical challenge. However, different pilot experiments carried out by Japanese (Suyehiro et al., 1992), French (Montagner et al., 1994a, 1994b, 1994c), and American groups (OSN1,

Dziewonski et al., 1992; Orcutt, pers. com., 1998) demonstrate that there are technical solutions to all the associated problems. The technical goal of the French Pilot Experiment OFM/SESMOBS (Observatoire Fond de Mer) conducted in April and May 1992 was to show the feasibility of installing and recovering two sets of three-component broadband seismometers; one inside an ODP borehole and another inside an ocean-bottom seismometer (OBS) sphere in the vicinity of the hole. It is possible to consider installing joint observatories to meet the needs of all these programs. During two workshops, IRIS in 1993 (Hawaii) and ION-ODP in 1995 (Marseilles), it was recognized that the installation of a Geophysical Ocean Bottom Observatory (GOBO) is now technologically feasible and represents their highest priority.

NERO Hole 1107A

The observatory planned for the Ninetyeast Ridge will be part of the future network of seafloor observatories proposed in the International Ocean Network (ION) program. Site 1107 on the Ninetyeast Ridge was selected near ODP Site 757 (Fig. 1) which was drilled during ODP Leg 121 (Pierce et al., 1989).

Installing a reentry cone and casing down to basement during Leg 179 was the first step toward the installation of a Geophysical Ocean Bottom Observatory (GOBO). The permanent seismometer instrumentation will be installed at a later date. Lessons learned from the OSN-1 Site off Hawaii indicate that noise levels can be a considerable deterrent in obtaining high quality seismic data. The goal was to establish a borehole cased and cemented past the sediment-basement interface and deepened to the extent possible. Of considerable importance was deepening the borehole so that the seismic sonde (~ 10 m long) would be coupled to the borehole wall in basement rock below the casing and not be close to, or clamped onto, the casing, as was the case in OSN-1 where noise levels may be high as a consequence. There is a possibility that the ocean bottom currents impinging on the reentry funnel on the seafloor can impart noise to the casing pipe and

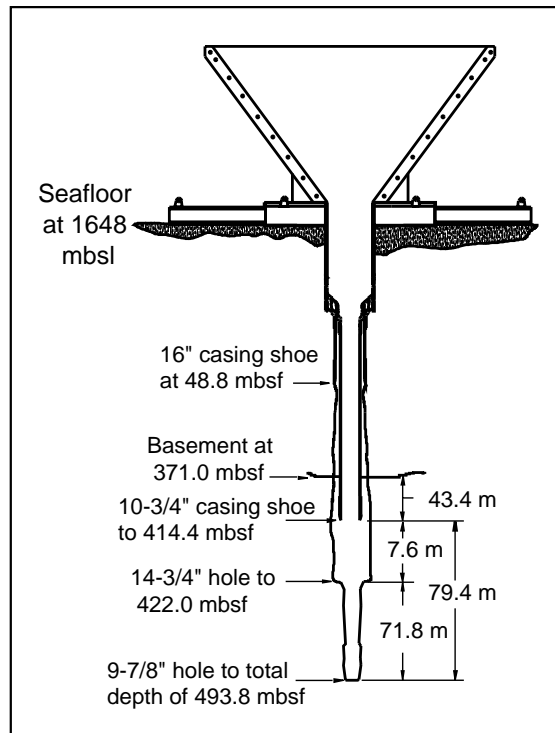

Figure 2: Schematic illustration of the completed cased borehole configuration and reentry funnel at NERO Hole 1107A to be utilized for installation of the Geophysical Ocean Bottom Observatory.

seismometer, especially if the sonde is attached to, or close to the bottom of the casing and if the casing is poorly cemented.

Initial operations at Hole 1107A involved washing-in 48.82 m of 16 in casing fixed to a reentry cone. The hole was then deepened to allow deployment of 10-3/4 in casing some 30-40 m into basement. Based on Leg 121 statistics, it was anticipated that ~12 hours would be required to drill to basement, and additional ~10 hours to drill at least 30-40 m into basement. Drilling the sediment column, however, took longer than expected, probably due to the size of the hole we were drilling and resistive layers of volcanic breccia and tuff overlying basement (Pierce et al., 1989). Basement drilling also proceeded somewhat slower than expected, although penetration rates were quite variable in the subaerially emplaced lava flows. At about 410 mbsf, a relatively hard layer was encountered, and ROP slowed to less than 2 m/hr. In light of the fact that drilling in basement had up to this point proceeded reasonably quickly, it was envisioned this hard layer as an ideal position to anchor the bottom of the casing with cement. After drilling to 422 mbsf to ensure that any material wiped off the walls of the borehole during emplacement of the casing would have a place to go and not impede casing operations, deepening was terminated in Hole 1107A because we had reached our target depth for casing of approximately 40 m into basement.

At this point in our operations, individually minor but collectively significant delays due to handling pipe in heavy seas, slowed ROP, and mechanical difficulties had contributed to a drastically reduced timetable. By the time the last casing operation was completed (10-3/4 in casing set to 414 mbsf), it was recognized there would not be sufficient time to clean out the cement shoe in the bottom of the casing, drill through the cement, clean out the rat hole underneath and make 10 m of new hole below the casing string. This was the absolute minimum envisioned as necessary for establishing a borehole for the observatory emplacement. A tricone bit, rather than a coring bit, was used to ensure penetration through the casing shoe without delay. This bit, although not allowing coring of the material drilled, did allow rapid penetration through the formation. Drilling continued to a depth of 493.8 mbsf — just over 120 m into basement and almost 80 m below the casing shoe (Fig. 2). This depth should allow a successful installation of the Ninetyeast Ridge Observatory.

During drilling through the sediment/basement interface and into basement, seismic-while-drilling data via OBS and the shipboard accelerometer was collected. However, all other ancillary ob-

jectives of the leg could not be achieved because of the unfortunate and considerable amount of operational time lost. Despite the disappointment regarding cancellation of the two-ship experiment, the German research vessel *Sonne* conducted a seismic survey using 25 ocean bottom seismometers and hydrophones while the *JOIDES Resolution* was conducting drilling operations at Site 1107. The two USGS OBSs deployed during the Leg 179 SWD experiments also recorded clear P and S wave arrivals from four lines shot with the *Sonne's* airguns.

Leg 179 Shipboard Scientific Party

John F. Casey, Chief Scientist, University of Houston, TX, USA; Jay Miller, Staff Scientist, ODP, Texas A&M University, College Station, TX, USA; Greg Myers, Remi Boissonas, Steve Kittredge, Leo Holloway, Thomas L. Pettigrew, Kuro Kuroki, Jo Robbens, Anne Pimmel, Erinn McCarty, Roy Davis, Erik Moortgat, John Dyke, Chris Nugent, Jaquelyn Ledbetter, Margaret Hastedt, Chris Stephens.

REFERENCES

- Dick, H. J. B., Schouten, H., Meyer, P.S., Gallo, D.G., Bergh, H., Tyce, R., Patriat, P., Johnson, K.T.M., Snow, J., and Fisher, A., 1991. Bathymetric map of the Atlantis II Fracture Zone, Southwest Indian Ridge. *In*: Von Herzen, R. P., Robinson, P. T., et al. (Eds), *Proc. ODP, Sci. Results*, 118 College Station, TX (Ocean Drilling Program).
- Dziewonski, A., Wilkens, R., Firth, J., and Shipboard Scientific Party, 1992. Background and objectives of the Ocean Seismographic Network and Leg 136 drilling results. *Proc. ODP, Init. Repts*, 136 College Station, TX (Ocean Drilling Program), 3-8.
- Montagner, J.P., Karczewski, J.F., and Romanowicz, B., 1994a. A first step toward an oceanic geophysical observatory. *Eos*, 75150-154.
- Montagner, J.P., Karczewski, J.F., Floury, L., and Tarits, P., 1994b. Towards a geophysical ocean bottom observatory. *Seismic Waves*, 37-9.
- Montagner, J.P., Karczewski, J.F., Romanowicz, B., Bouaricha, S., Lognonn, P., Roult, G., Stutzmann, E., Thiriot, J.L., Brion, J., Dole, B., Fouassier, D., Koenig, J.C., Savary, J., Floury, L., Dupond, J., Echerdour, A., Floc'h, H., 1994c. The French pilot experiment OFM/SISMOBS experiment; first scientific results on noise level and event detection. *Phys. Earth Planet. Int.*, 84321-336.
- Suyehiro, K., Kanazawa, T., Hirata, N., Shinohara, M., and Kinoshita, H., 1992. Broadband downhole digital seismometer experiment at Site 794. *Proc. ODP, Sci. Results*, 127/128 College Station, TX (Ocean Drilling Program).
- Pierce, J., Weissel, J., et al., 1989. *Proc. ODP Init. Repts*, 121, College Station, TX (Ocean Drilling Program). ❖

Hammer Drill: An Overview and Post Leg 179 Update

by Tom L. Pettigrew and G. Leon Holloway

A long-standing challenge to the Ocean Drilling Program (ODP) as a whole, and in particular ODP/TAMU (Texas A&M University) Operations and Engineering Teams, has been the establishment of stable reenterable boreholes in fractured hard rock formations with little or no sediment cover. Sites such as the Mid-Atlantic Ridge near the Kane Fracture Transform (MARK) and Hess Deep are prime examples. As if this challenge alone is not enough, most of the sites of interest are on slopes of 30 degrees or more and covered with talus, making them highly unstable drilling platforms. Several techniques have been used by ODP in an attempt to meet this challenge, including unsupported conventional rotary spudding and the use of hard rock guide bases. Unsupported conventional rotary drilling techniques have actually been quite successful. However, holes drilled or cored in this manner are "single-bit" holes (not considered reenterable) and seldom reach below 80 mbsf. A 200 m-deep hole at MARK (Cannat et al., 1995) is the exception, but the drilling assembly is still in that hole. The hard rock guide base has been deployed with limited success. The most notable success is Hole 735B, drilled to 1508 mbsf on a wave cut platform near the Atlantis II Fracture Zone (Natland et al., this issue). However, on talus-covered slopes, the hard rock guide base has not proven to be a reliable tool.

The latest approach to establishing a stable reenterable borehole in fractured hard rock formations is the development of some form of drill-in casing system that does not rely on seafloor stabilization. Casing is routinely drilled-in by the petroleum industry using conventional oil field under reamers. However, oil field under reamers rely on conventional rotary drilling techniques (i.e., rotation of the drill bit with large loads, or weight on bit, applied to the drill bit). When drilling with an unsupported drilling assembly, the weight on bit must be kept low to minimize leaning and buckling of the drilling assembly. Thus, when spudding hard rock with conventional rotary drilling systems, rates of penetration are very low, which in turn results in long drilling times with an unsupported drilling assembly. The longer the drilling assembly is rotated unsupported, the higher the risk of damage to, or failure of, the drilling assembly. Therefore, consideration of any conventional rotary drilling technique has been discarded in favor of a modified hard rock drill-in casing system commonly used in the geothermal and construction industries: the hammer drill.

Hammer Drill-In Casing System

As the name implies, the hammer drill-in casing system uses a hammer, in the form of a large reciprocating weight, to drive the drill bit into the formation, micro-fracturing the rock. Slow rotation of the hammer drill is required only for indexing the tungsten carbide cutters on the drill bit. Because the drilling mechanism is percussion, the hammer drill requires very low weight on bit while drilling, which is a definite advantage when drilling with an unsupported drilling assembly.

When the hammer drill-in casing project was undertaken by ODP, there were not many hydraulic hammer drills commercially available — of those available, none was specifically designed for drilling in large diameter casing. Common ODP operations in deep water, however, require a hydraulically-driven hammer system rather than a pneumatically-driven one as conventionally used on land. Only one vendor offered a hydraulic hammer that was thought to be potentially usable by ODP. Thus, a cooperative effort was initiated between ODP and that vendor to develop a hydraulically-driven hammer drill specifically for ODP. This cooperative effort led to the development of a hydraulic or water-powered hammer drill suitable for drilling-in 13-3/8-in casing (Fig. 1). The water-powered hammer drill was integrated with basic off-the-shelf under reaming hammer drill bits and a special casing suspension system designed at ODP/TAMU to form the hammer drill system. After land testing of the hammer drill system was completed, it was time to attempt the first-ever deployment of a water-powered hammer drill-in casing system from a ship in deep water.

Leg 179 Hammer Drill Testing

The first half of Leg 179 was devoted to testing the new hammer drill system concept at sea. The site chosen for the testing was in the vicinity of Hole 735B on the same wave-cut platform near the Atlantis II Fracture Zone (Casey et al., this issue). The primary objectives for the Leg 179 hammer drill system concept evaluation at sea were as follows:

- Determine the operational characteristics of the hammer as observed from the rig floor of the *JOIDES Resolution*.
- Determine the viability of the complete hammer drill system (i.e., its ability to emplace casing in fractured hard rock, optimum operational procedures, etc.).
- Determine the operational limits of the hammer

T. Pettigrew is Engineering Advisor and L. Holloway is Senior Development Engineer, both at ODP, Texas A&M University.

drill system (i.e., maximum slope spudding capability, maximum rubble penetration capability, etc.).

Determining the operational characteristics of the hammer drill involved deploying just the hammer drill (without casing) and attempting multiple hole spuddings. The water hammer operated very well and its operational characteristics were determined. Unfortunately, there was the tendency for failure of the under reaming drill bits while spudding. Thus, the viability and operational limits of the overall system were not tested.

The under reaming hammer drill bits proved to be the Achilles' heel. There were two basic types of under reaming drill bits tested: concentric and eccentric. Both types of under reaming drill bits failed from overloading of the under reaming mechanisms (i.e., under reaming arms and eccentric). The failures were caused by the unsupported drilling assembly leaning over, causing the under reaming drill bits to be rotated about the horizontal plane (perpendicular to the drill string axis) while spudding. This "rocking" of the under reaming drill bit while spudding caused high loads to be placed on the low side of the under reaming arms and eccentric. The high loading sheared off the tungsten carbide insert cutters and severely abraded the under reaming arms and eccentric bodies, which in turn prevented the drill bit from advancing the borehole. However, it is encouraging to note that the pilot portion of all the under reaming bits came out of the hole in good condition. Also, a standard hammer drill drilling bit was used in Holes 1106C and 1106D, and showed no signs of wear while achieving a penetration rate of 4.8 m/hr in Hole 1106E in massive gabbro. These are all indications that the hammer drill can drill subsea

hard rock formations given the proper drill bit configuration.

Another problem that hampered the Leg 179 testing was severe vibrations in the pumping system. The vibrations were a result of high-frequency pressure pulsations set up by opening and closing of the hammer piston control valve. The vibrations were directly proportional to flow rate and pressure. Therefore, although testing could be carried out, the flow rate had to be maintained below optimum performance levels to reduce the vibrations to an acceptable level.

Compounding the vibration problem was the large heave incurred during Leg 179. The heave could not be fully compensated for by the limited weight-on-bit that can be applied when spudding or drilling with an unsupported drilling assembly. The residual heave that could not be compensated by the drill string heave caused the hammer to be pulled clear of the bottom while spudding. When the drill bit is not in contact with the bottom, the hammer mechanism is by-passed by activation of an internal valve allowing flow through the hammer which results in cessation of the hammer operation. Unfortunately, the only way to overcome the large heave problem was to increase the weight-on-bit which resulted in an increasing tendency for the drilling assembly to lean, thereby exacerbating the failure of the under reaming drill bits.

Post Leg 179 Hammer Drill Review, Action and future development

The preliminary assessment of the Leg 179 hammer drill test results indicates that the hammer drill shows promise of being able to penetrate subsea hard rock environments. A complete, detailed review of the Leg 179 test results is currently underway. Several aspects of the hammer drill system that were highlighted during the Leg 179 testing as needing additional development have been identified.

The heart of the system, the water hammer, is considered to be a working prototype tool requiring only minor upgrading at this time. A dialogue has already been established with the hammer vendor to investigate the minor problems encountered with the hammer through redesign of specific parts within the hammer.

A two-pronged approach to solving the under reaming drill bit failures is underway. In collaboration with the manufacturers, a new under reaming drill bit design is envisaged to meet ODP's unique drilling conditions (i.e., bare, hard rock spudding, deep water operations, operating from a floating platform, and having to spud or drill with an unsupported drilling assembly). In addition, different under reaming drill bits and casing shoe configura-

Figure 1: Schematic diagram illustrating the deployment of the water powered hammer drill-in casing system.

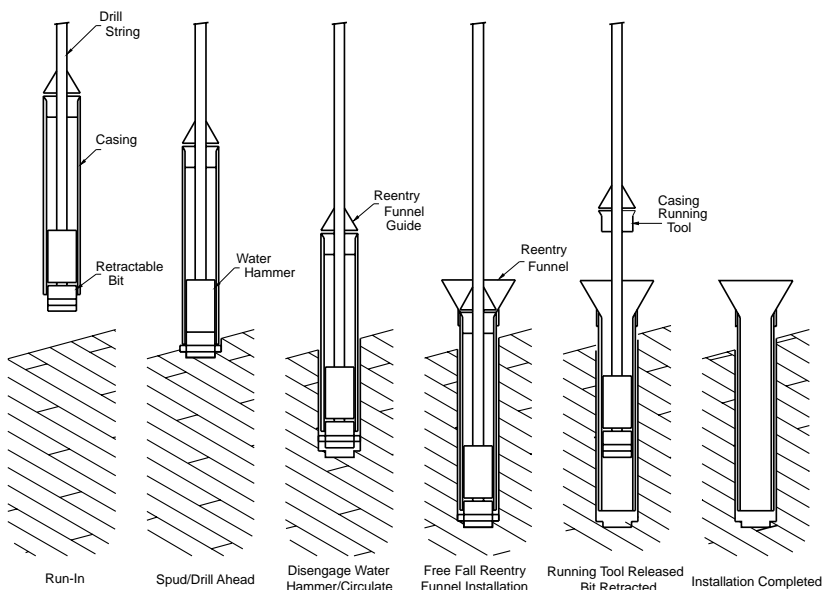

tions are being investigated. Already existing configurations warrant further detailed review and possible testing.

The pumping system vibration problem is also being investigated through a two-pronged approach. The capability of the existing pump pulsation dampers compared with off-the-shelf commercially available pump pulsation dampers is being examined. In addition, downhole pulsation reflectors, reported to not only reduce the pulsation-induced vibrations but also to increase the hammer efficiency, are being investigated.

Eliminating the residual heave is perhaps the most difficult problem to solve. Off-the-shelf commercially available downhole tools, such as thruster subs and bumper subs, may be capable of reducing the residual heave problem if not eliminating it, and are being evaluated.

Thus, the Leg 179 test provided a wealth of data and a clear direction to proceed in further de-

velopment of the hammer drill system. Confidence remains high that the hammer drill system can be modified to work efficiently and thus improve ODP's ability to service that segment of the science community interested in hard rock investigations. The first step will be to land test these new and different under reaming drill bit technologies and configurations, and then integrate the most promising two or three into the hammer drill system. Once this has been accomplished a new testing at sea will be required. The current development plan calls for having the hammer drill system ready for testing at sea again just before or immediately after dry dock in August to October 1999.

REFERENCE

Cannat, M., Karson, J.A., Miller, D.J. et al., 1995. Proc. ODP, Init. Repts, 153: College Station, TX (Ocean Drilling Program). ♦

Leg 177 – Continued from page 6

cial cycles of the Plio-Pleistocene, and the long-term evolution of the Antarctic ocean-cryosphere system during the Cenozoic.

Leg 177 Shipboard Scientific Party

Rainer Gersonde, Co-Chief Scientist, Alfred Wegener Institute for Polar and Marine Research, Bremerhaven, Germany; David Hodell, Co-Chief Scientist, University of Florida, Dept. of Geology, Gainesville, Florida; Peter Blum, Staff Scientist, ODP, Texas A&M University, College Station, Texas; Eva Carin Andersson, William Austin, Katharina Billups, James Channell, Christopher Charles, Bernhard Diekmann, Gabriel Filippelli, Jose-Abel Flores, Tony Hewitt, William Howard, Minoru Ikehara, Thomas Janecek, Sharon Kanfoush, Alan Kemp, Stagg King, Helga Kleiven, Gerhard Kuhn, Maria Marino, Ulysses Ninnemann, Suzanne O'Connell, Joseph Ortiz, Joseph Stoner, Kazuhiro Sugiyama, Detlef Warnke, Ulrich Zielinski.

REFERENCES

Bohrmann, G., Abelman, A., Gersonde, R., Hubberten, H. and Kuhn, G., 1994. Pure siliceous ooze, a diagenetic environment for early chert formation, *Geology*, 22, 207-210.

Charles, C.D., Lynch-Stieglitz, J., Ninnemann, U.S. and Fairbanks, R.G., 1996. Climate connections between the hemispheres revealed by deep sea sediment core/ice core correlations. *Earth Planet. Sci. Letts.*, 142, 19-27.

Kemp, A.E.S. and Baldauf, J.G., 1993. Vast Neogene laminated diatom mat deposits from the eastern equatorial Pacific Ocean, *Nature*, 362, 141-144.

Kennett, J.P., 1977. Cenozoic evolution of Antarctic glaciation, the circum-Antarctic Ocean, and their impact on global paleoceanography, *J. Geophys. Res.*, 82, 3843-3860.

Mix, A.C., Le, J. and Shackleton, N.J., 1995. Benthic foraminiferal stable isotope stratigraphy of Site 846: 0-1.8 Ma. In: Pisias, N.G., Mayer, L.A., Janecek, T.R., Palmer-Julson, A. and van Andel, T.H. (Eds), *Proc. ODP, Sci. Results*, 138: College Station, TX (Ocean Drilling Program), 839-854.

Ortiz, J.D., Harris, S.E., Mix, A.C. and the Leg 177 Shipboard Scientific Party, 1998. SCAT reflectance: shedding light on sediment mineralogy. *JOI/USSAC Newsletter*, 11(2), 14-20.

Petit, J.R., Basile, I., Leruyet, A., Raynaud, D., Lorius, C., Jouzel, J., Stievenard, M., Lipenkov, V.Y., Barkov, N.I., Kudryashov, B.-B., Davis, M., Saltzman, E. and Kotlyakov, V., 1997. Four climatic cycles in Vostok ice core, *Nature*, 387, 121-164.

Weedon, G.P., Shackleton, N.J. and Pearson, P.N., 1997. The Oligocene time scale and cyclostratigraphy on the Ceara Rise, western equatorial Atlantic. In: Shackleton, N.J., Curry, W.B., Richter, C., and Bralower, T.J. (Eds), *Proc. ODP, Sci. Results*, 154: College Station, TX (Ocean Drilling Program), 101-114, 1997. ♦

Measurement-While-Coring in ODP — Success During
Leg 179 and the Road Ahead

by **D. Goldberg, G. Myers, A. Meltser, E. Scholz, and
the Leg 179 Shipboard Scientific party**

During Leg 179, we set out to explore the use of drilling data collected outside, rather than inside, the drill pipe. In the course of everyday operations on board the *JOIDES Resolution*, the drillstring vibrates continuously. These vibrations are characteristic and can be acquired at the rig floor or at the drill-bit, although the latter provides a more accurate signature of the environment being drilled. The ultimate goal is to evaluate whether these reverberations, generated from the formation and environment encountered at the bit, by ship heave motions, and from other extraneous noise sources, can be used to improve operations. If so, new technology development for more routine use of measurement-while-coring and for active heave compensation (Bollfrass & Miller, this issue) may prove to be worthwhile undertakings for ODP.

In the initial experiments conducted during Leg 179, drillstring signals were detected above the rig floor. We developed a pilot sensor and placed it immediately below the top drive to record one vertical and two axial components of the drillstring vibration. Such measurements have never be-

fore been recorded in ODP or on other deep-water drilling rigs.

These drillstring tests were performed in parallel with two Seismic-While-Drilling (SWD) experiments conducted in the central and southwest Indian Ocean. In typical SWD experiments, the force of a roller cone drill-bit impacting the formation generates energy which radiates axially and is received by sensors located on the seafloor (Rector and Marion, 1991). The pilot sensor is used to record the axial vibrations that travel up the drillstring, representing the drill-bit source signal (Meehan et al., 1998). This type of experiment can be described as a “reverse” vertical seismic profile (VSP) where the source is usually at the surface and the receivers are placed at various levels in a borehole. During Leg 179, an ocean bottom seismometer (OBS) array was deployed twice, once each near Hole 1105A and Hole 1107A (Casey et al., this issue). A global positioning system (GPS) was used to synchronize time data collected from the pilot sensor and the OBS array. These data are being reduced and correlated post-cruise.

The pilot sensor assembly used during Leg 179 consisted of one three-axis accelerometer, batteries, an alloy wedge clamp, and a wireless data transmission modem (Fig. 1). The system has sufficient battery power to operate continuously for up to 72 hours. Two antipodal antennas in the rotating pilot sensor enable signals to be transmitted without interruption to the Downhole Measurements Laboratory (DHML). By clamping mechanically to a 1.5-m sub just below the top drive, the installed pilot sensor did not interfere with the normal drilling process because the drilling crew was still able to use the iron roughneck to connect pipe joints.

Leg 179 Results

During May 1998, the pilot sensor ran for a total of nearly 100 hours at Sites 1105 and 1107. Data were recorded from 33.3 m below seafloor (mbsf) to 106.5 mbsf in Hole 1105A and from 170.6 to 422.0 mbsf in Hole 1107A. Drilling conditions were similar at both sites in terms of rotation and pump rates; however, the water depth, and thus the weight of the drillstring, were considerably greater at Site 1107 than at Site 1105 (water depths of 1659 m and 714 m, respectively). In addition, a four roller-cone bit was used to drill gab-bro at Site 1105 and a three roller-cone bit was

Figure 1: Schematic diagram of the pilot sensor system used to measure drillstring acceleration during Leg 179. Data were acquired in parallel with a Seismic-While-Drilling (SWD) experiment at Site 1105 and 1107 in the southwest and central Indian Ocean.

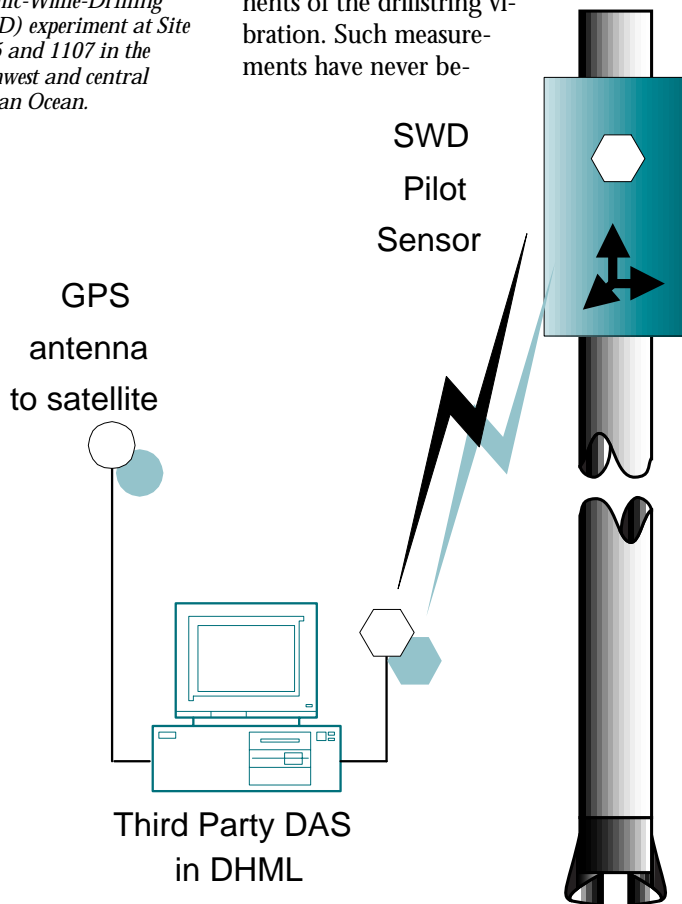

used in sediments and basalt at Site 1107. The drill-bit differences, in particular, were clearly seen in the pilot sensor results.

Figure 2 illustrates the relative power spectra of the components of acceleration in basalt at Site 1107 and in gabbro at Site 1105, respectively. The bit rotation rate can be identified by the small spectral peak at 0.8-1.0 Hz, corresponding to 50-60 rev/min. The large peaks are associated with the rotation rate of each roller-cone as the bit turns one revolution. The four rollers used in the gabbro rotate faster than the three in the basalt. The vertical acceleration in the gabbro also contains significant energy at high frequencies, which is absent in basalt, and considerably more energy on the horizontal than on the vertical axis component (Fig. 2c). The ratio of signal amplitude between the axes is approximately 6:1 at this depth. The signal amplitude in sediments (not shown) is roughly half that in either basalt or gabbro, regardless of the water depth. These differences show important characteristics of the advancing drill-bit — significant energy radiates through the seafloor and differently through various formations; thus, it is useful for SWD experiments and for evaluation of drilling conditions in ODP environments.

Other signals are also present in these spectra. Every rig floor operation, as well as other ship vibrations, creates noise. Spectral signatures are observed, for example, when the iron roughneck is used to connect sequential lengths of pipe, when the main motors rev to rack or pick up pipe joints, or when the elevators are clamped on a drill collar. In order to isolate and identify these noise sources, the pilot sensor was removed from the top drive and placed outside the DHML for several minutes during a bit trip at Site 1105. Rig floor and ship operations punctuated the spectra during this test. Of these, the most important sources of noise appear to be the ship's motors at 15-16 Hz and the lab fans at 41 Hz, both of which overlap with the formation signals generated during drilling. These noise sources increased as loads were added (e.g. motors picking up pipe), but their overall amplitude remained 7-10 times lower than that generated during drilling and is likely of minor importance in the drill-bit signal for this deep water setting. Other noise may be generated from non-periodic sources such as the hydraulic pumps, which work hard when the top drive is rotating and when the iron roughneck is making or breaking pipe connections, thruster activity in rough seas, banging of the drillstring in the guide horn, and residual low-frequency heave that is not completely removed by signal conditioning. These noise sources have not been isolated in our initial tests.

The Next Steps

New information about the environment encountered by the drill-bit, ship heave motions, and other drilling-related reverberations is on the horizon. Armed with such data, long-unresolved problems in ODP concerning drill-bit control, pipe depth, the co-registration of core and log depths, and heave compensation can be quantitatively addressed. We suggest the following three-step approach over the near-term to evaluate the need for routine measurement while coring in ODP (Fig. 3):

1. Measure additional drilling parameters with the rig floor recording system.
2. Adapt coring tools to measure downhole acceleration and other parameters in memory.
3. Use off-the-shelf commercial technology to transmit drilling parameters only (without coring) to the surface in real time.

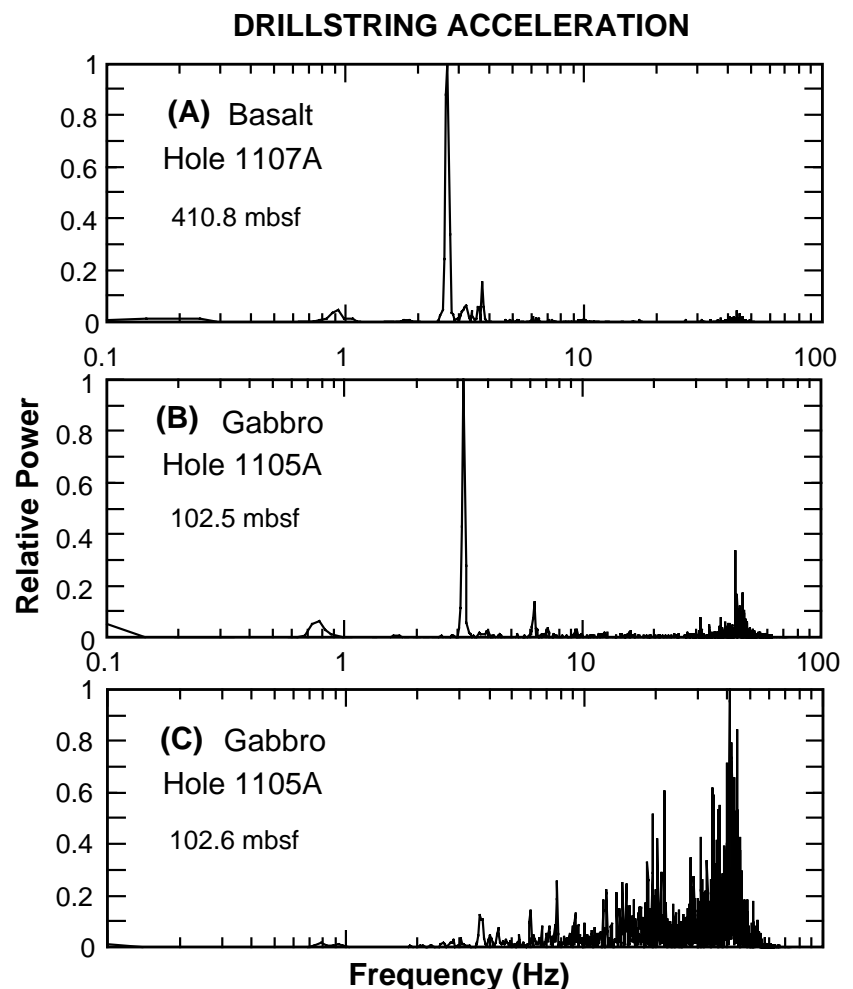

Figure 2: Spectra of acceleration signals recorded over 20 s periods using the pilot sensor system. (A) Vertical acceleration spectra in Hole 1107A. Note spectral peaks at 1 Hz and 2.7 Hz are attributed to the pipe and three roller-cone bit rotation rates, respectively. (B) Vertical acceleration spectra in Hole 1105A. Spectral peaks at 0.8 Hz and 3.2 Hz are attributed to drillpipe and four roller-cone bit rotation rates, respectively. The signal amplitude in (A) and (B) is approximately equal, although more high-frequency energy is present in (B). (C) Horizontal acceleration spectra in Hole 1105A. The ratio of signal amplitude between (C) and (B) is 6:1. Large spectral peaks due to rig noise at 15 Hz and 41 Hz have relatively low amplitude with respect to the drill-bit signal.

None of these steps requires a major technological development effort. With the encouraging success of the pilot sensor measurements, adding other drilling parameters such as depth, weight, torque, and pump rate to the high-resolution recording system used during Leg 179 is a logical first step. In addition to such measurements at the rig floor, data acquired at the bit may provide a more accurate representation of the drilling environment. To achieve this second step, a downhole tool is currently being adapted by LDEO and TAMU to measure acceleration in memory during conventional ODP coring operations. Additional measurements, such as the penetration angle of the core barrel, will be added to this tool and may prove to be useful in evaluating the success of each coring run. Data measured at the bit can also be

transmitted to the surface in real time to help the drillers improve performance. Although usually operating without continuous core recovery, commercial rigs routinely use a mud-pulsing system to acquire parameters related to the drilling process itself in real time (e.g. Murphy, 1993). With no development effort, conventional Logging-While-Drilling (LWD) tools can be augmented to transmit these drilling parameters using mud-pulsing (MWD) technology.

These three steps should be realized prior to undertaking substantial effort for other related technological developments in ODP. In particular, the comparison of rig-to-downhole acceleration (step 2) will allow a critical evaluation of the effectiveness of the passive heave compensation system currently used during coring (e.g. Goldberg, 1990). The dynamics of the pipe should be carefully considered before development of an active compensation system begins. Also, acquiring drilling information in real-time may or may not prove to be essential for deep-water ODP operations. Evaluation of real-time information about the drilling process alone, without coring, can be accomplished using existing MWD technology (step 3). This off-the-shelf experiment, if successful in improving ODP's drilling effectiveness, might justify the development of real-time transmission while coring. These three steps can be accomplished quickly. A review of their results will determine whether these developments are important new capabilities for ODP's future.

Leg 179 Shipboard Scientific Party

John F. Casey, Chief Scientist, University of Houston, TX, USA; Jay Miller, Staff Scientist, ODP, Texas A&M University, College Station, TX, USA; Greg Myers, Remi Boissonas, Steve Kittredge, Leo Holloway, Thomas L. Pettigrew, Kuro Kuroki, Jo Robbens, Anne Pimmel, Erinn McCarty, Roy Davis, Erik Moortgat, John Dyke, Chris Nugent, Jaquelyn Ledbetter, Margaret Hastedt, Chris Stephens.

REFERENCES

Goldberg, D., 1990. Test performance of the Ocean Drilling Program wireline heave motion compensator, *Scientific Drilling*, 1: 206-209.
 Meehan, R., Nutt, L., Dutta, N. and J. Menzies, J., 1998. Seismic information helps predict drilling hazards, choose casing point, *Oil & Gas Journal*, 96(19): 53-60.
 Murphy, D. P., 1993. What's new in MWD and formation evaluation, *World Oil*, 214: 47-52.
 Rector, J. W. and Marion, B. P., 1991, The use of drill bit energy as a downhole seismic source, *Geophysics*, 56: 628-634. ❖

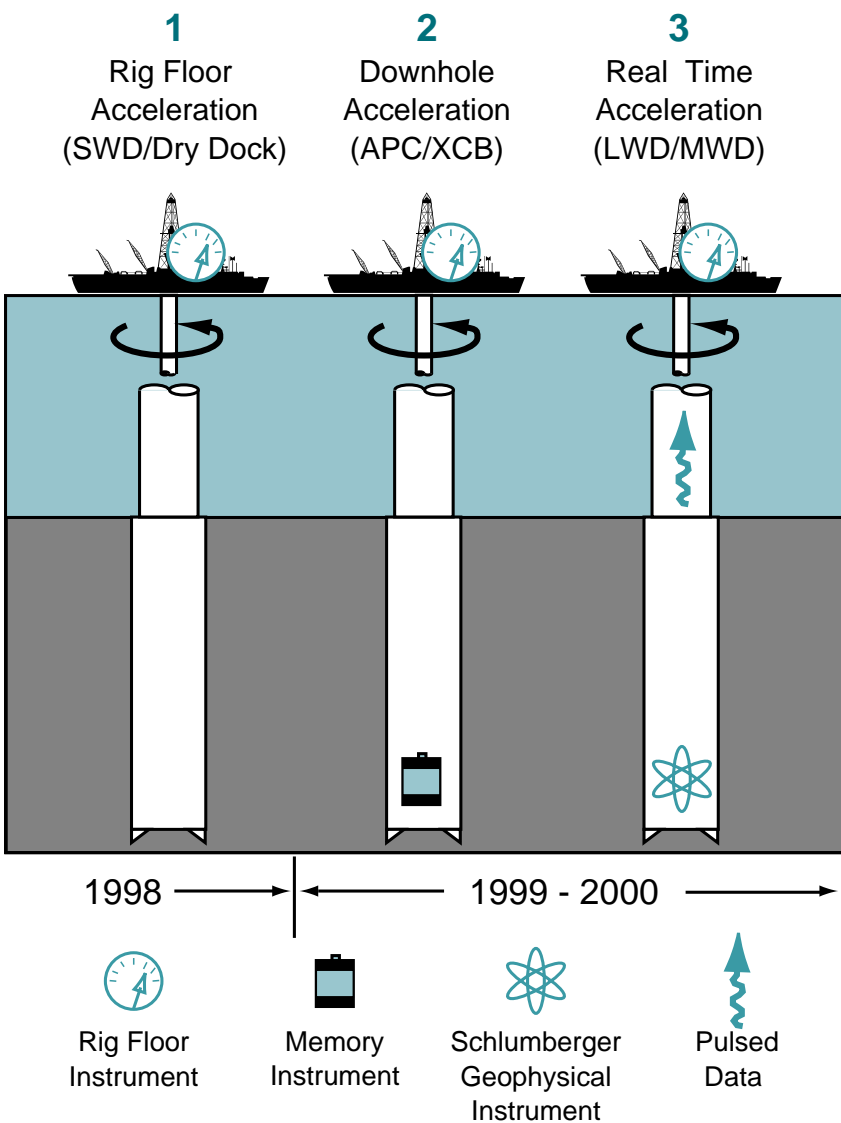

Figure 3: Cartoon illustrating the sequence of developments for measurement while coring in ODP. (1) The pilot sensor system recorded drillstring acceleration during Leg 179. Additional instruments will be added to record drilling parameters at the rig floor during 1999. (2) Adaptation of a memory tool to measure downhole acceleration during conventional coring operations. (3) Transmission of downhole parameters to the surface using commercial mud-pulse technology in combination with conventional LWD tools.

Activation of the Drill String Compensator on Board the JOIDES Resolution

by Buddy Bollfrass and Jay Miller

Drilling operations at sea are greatly affected by the motion of the drilling platform relative to the sea floor. While there are several contributing factors to this motion (e.g. offset due to dynamic ship positioning and lateral displacement of the drill pipe by ocean currents), by far the most derogatory to shipboard operations is drill string heave (vertical displacement) realized at the drill bit. Current operations on the *JOIDES Resolution* are enhanced through the use of a passive heave compensation system (Fig. 1), whereby heave is ameliorated by giant shock absorbers. Thus, improved coring performance is achieved by nearly negating the effects of heave in moderate sea states (< 2-3 m of ship heave). However, at higher sea states (> 3 m of ship heave), which are virtually ubiquitous in deep sea drilling operations, the effectiveness of passive heave compensation exponentially decreases.

Most floating drilling platforms are supported on parallel, submerged hulls (semi-submersibles) that dampen rig floor heave. Operations on drill ships, however, are much more seriously impacted by heave, and performance contracts universally allow for time lost to the effects of high sea states. Based on safety and other operational conditions, ODP activities are suspended when ship (rig floor) heave approaches 7 m (roughly 3 m of compensated drill string motion). On the other hand, many tools that are used to enhance recovery and rate of penetration (ROP)

on land cannot be effectively deployed at sea when drill string heave exceeds 1 m (< 3 m rig floor heave). Since the duration of ODP expeditions is fixed, time lost to sea state directly impacts achieving the objectives of scientific ocean drilling. Additionally, excessive heave indirectly affects our ability to reach these objectives by limiting the variety of tools at our disposal.

The Long Range Plan of the Ocean Drilling Program specifically targets technological innova-

tion as a requirement for delivery of science objectives over the next few years of the Program. The most universal limitation to all operations at sea is drill string heave, which reduces recovery and can even prevent deployment of our conventional and specially adapted coring tools. If drill string heave could be moderated more effectively, ODP could reduce the amount of time lost to high heave (thus increasing time dedicated to coring and other operations) and employ a greater array of new and proven technologies to improve recovery and ROP.

In response to the migration of the international exploration drilling industry to deeper water with inherently higher sea states, a new technology, Active Heave Compensation (AHC), has been developed and recently deployed that delivers significantly improved heave reduction. Installation on the *JOIDES Resolution* will immediately and favorably impact coring and downhole operations.

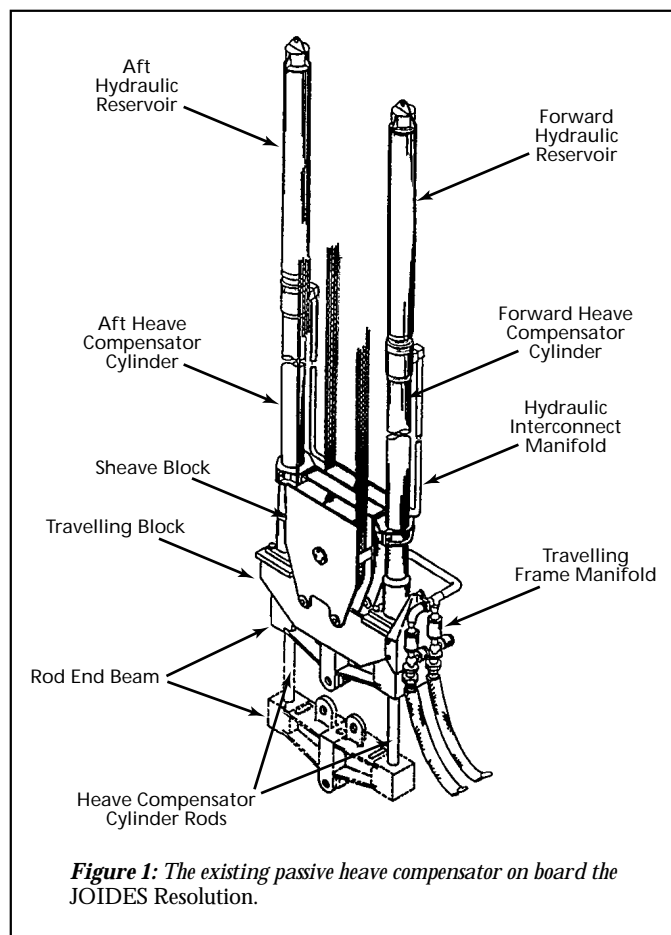

Figure 1: The existing passive heave compensator on board the *JOIDES Resolution*.

Buddy Bollfrass is Development Engineering Supervisor and D. Jay Miller is Staff Scientist, both at ODP, Texas A&M University.

Active Heave Compensation

ODP's existing passive heave compensator operates with air compressed by drill string momentum, but its reaction time is restricted by friction and complicated by inharmonious motion. Engaging an active heave compensator (AHC) involves assisting the system with a hydraulic piston, such that fluid pressure is utilized to overcome frictional forces, thereby reducing the system time. The active heave compensator is driven by heave sensors (accelerometers mounted on the ship) with response time measured in microseconds, that radically reduce reaction time and drill string heave.

The efficiency of any heave compensator is compromised when the ship's natural heave response period is quicker than the compensator reaction time (Fig. 2). However, active compensators are not limited by seal friction or drill pipe momentum. Although vendors of AHC systems will only guarantee 70-80% efficiency, North Sea operators report an efficiency of 94-96%. Offshore drilling companies have installed active heave compensators on board many of their offshore drilling vessels, either derrick-top systems or in-line

(*JOIDES Resolution*) systems. SEDCO Forex (operator for ODP) has installed active heave compensation systems on four vessels. Since 1991, other operators have installed AHC on sixteen vessels.

Active systems are utilized in two modes: the landing mode and the drilling mode (Fig. 2). In the landing mode, the compensator strives to maintain the position of the bottom hole assembly (BHA), as in reentries, landing of CORKs or setting packers or instrumentation. In the drilling mode, the compensator strives to maintain a superimposed weight on the BHA, where operations require a softer response in order to rotary drill, or drill with mud motors or core.

Conversion of the existing heave compensator will cost approximately \$800,000 plus installation and crew training. The bid package being prepared has a target of dry dock (Aug-Oct 1999). The physical additions to the existing passive compensator on board the *JOIDES Resolution* will include a driver cylinder attached directly to the compensator, several pumps with an oil reservoir below the rig floor, and a computer control system that causes the active heave compensator to react to accelerometer measurements of ship heave (Fig. 3). If the active system becomes inoperative, the hydraulic driver cylinder can be by-passed to allow the resumption of passive compensation without loss of operating time.

Maintenance requirements are similar to existing equipment. The operational risk is the same as the passive compensator, but the benefit is reduced drill string heave in higher sea states to improve tool performance. The conversion cost is equivalent to about 15 days of normal leg contract costs, and its application will affect any leg where environmental conditions (2-4 m passively compensated drill string heave) limit tool performance.

Development Plan

A fundamental goal in the Long Range Plan for Phase III tool development on the *JOIDES Resolution* is to measure drilling characteristics at the BHA and compare them with drilling control parameters at the surface. This will allow tool performance to be diagnosed and operations to be improved by altering drilling controls and/or tools without pulling the drill string. The first step toward achieving this goal is to reduce ship heave in order to limit vertical displacement and weight variation at the bit. This can be accomplished by activating the existing compensator. The table (next page) documents the difference in estimated drill string heave between passive and active heave compensation systems.

Figure 2: Schematic diagram illustrating the efficiency of active and passive heave compensation in response to the ship's natural heave.

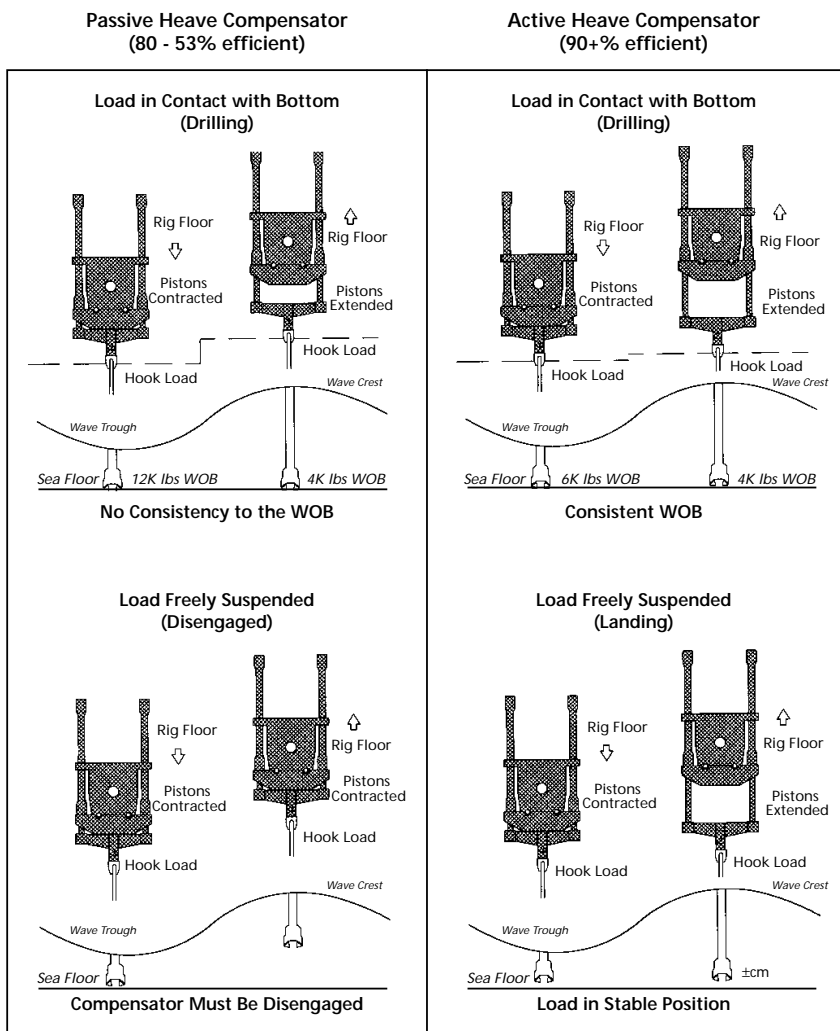

SHIP HEAVE (Swells + Waves)	DRILL STRING HEAVE (RIG FLOOR)	
	Passive HC	Active HC
1 - 3 m	0.2 - 0.6 m	0.1 - 0.3 m
4 - 6 m	1.3 - 2.0 m	0.4 - 0.6 m
7 - 9 m	3.3 - 4.2 m	0.7 - 0.9 m

These estimates, based on 80%/67%/53% efficiency of the passive HC and 90+% of the active HC, demonstrate the advantage of the active compensation system in reducing the ship-induced heave on the drill string in high operational sea states. The first drilling control parameters planned for routine measurement by ODP are ship heave and drill string heave at the rig floor. Drill string heave is currently estimated from drill string motion, and represents the difference between ship heave and string movement. It is important that these essential measurements be made before and after installation of the AHC, because future developments require an accurate knowledge of these parameters.

Subsequently, we intend to measure drilling characteristics at the BHA for comparison with drilling control parameters by the Operations Engineer at the rig floor, for diagnosis of downhole conditions by the Operations Manager, so that operations personnel can build a data base on which to react to improve tool performance and extend tool life. The final step is the adaptation of this process to real-time conditions as a Measurement-While-Coring system (Goldberg et al., this issue) so that diagnosis and reaction can be made without pulling the drill string.

Benefits

Active heave compensation should significantly reduce the vertical motion and bit pounding effect at the BHA. This would reduce core jamming in fractured rock and thus improve core recovery and quality in alternating hard/soft laminated sections by reducing core breakage and bit plugging. Higher speed, thin kerf diamond core bits offer the greatest promise for core recovery in hard rock and alternating hard/soft laminates. The effectiveness of diamond coring from the *JOIDES Resolution* should be increased by reducing the weight-on-bit (WOB) fluctuation through activation of the heave compensator. This will further allow employment of proven tools over a greater range of sea states and help to considerably reduce time lost to sea state. Bit pounding, when engaging the passive heave compensator and when coring with lighter WOB, aggravates early bit failures. By essentially stopping vertical motion at the BHA, an active heave compensator can make re-entries safer, and soften landings for both light and heavy loads (re-entry cones, hard rock guide bases, CORKs, packers and fluid flow or seismic devices).

Many of the scientific goals of Phase III (FY'98-FY'03) of the Long Range Plan can be achieved only by application of new tools that depend on WOB control, such as hydraulic hammers, diamond core bits, open-hole packers and downhole instrumentation. The effective performance of these tools in high operational seas is dependent on reducing the effect of ship heave on the drill string by installation of an industry-proven active heave compensation system on board the *JOIDES Resolution*. ❖

Passive Heave Compensator

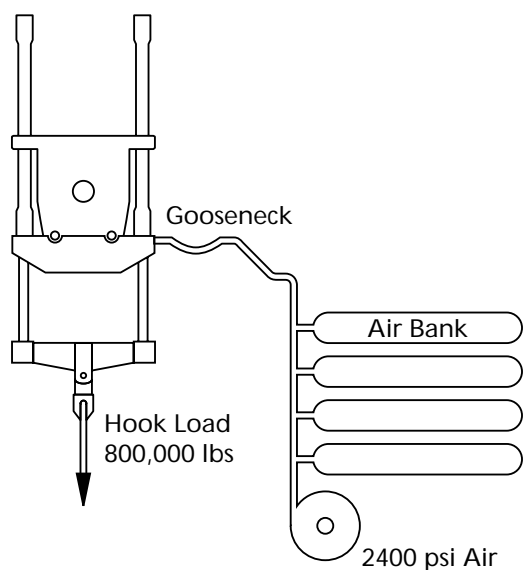

Active Heave Compensator

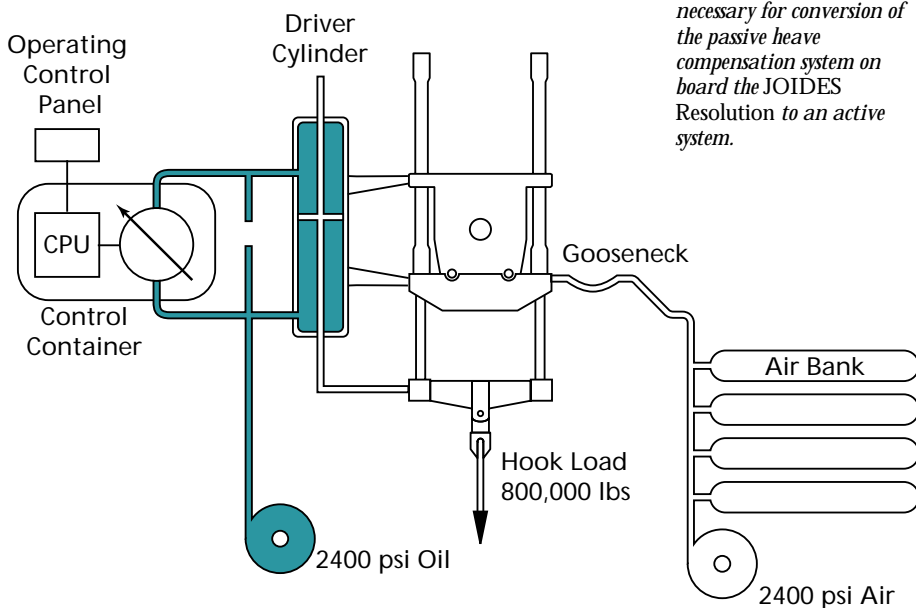

Figure 3: Schematic illustration outlining the technical additions necessary for conversion of the passive heave compensation system on board the JOIDES Resolution to an active system.

A Dry Dock for the JOIDES Resolution

by P. Jeff Fox

As the end of the Ocean Drilling Program approaches, and the range of drilling required for the achievement of the objectives of the Long Range Plan becomes more focused, it is apparent that much in the way of increased flexibility and endurance will be asked of the *JOIDES Resolution* in the coming years. Deep drilling and operations in extreme weather environments will challenge the vessel. The Program must look to the 1999 drydock as the ideal opportunity to enhance the vessel to meet its operational obligations. In this way, the amount of quality science that can be realized will be maximized.

Maintaining the *JOIDES Resolutions's* current American Bureau of Shipping (ABS) classification, which must be satisfactorily completed for insurance purposes, dictates that the vessel undergo a major dry dock and hull inspection every 5 years. In addition, and of overriding importance, the current contract with the vessel's owners ended on 30 Sept. 1998. In 1992, a MOA (Memorandum Of Agreement) was signed that laid the groundwork for extending the contract for an additional 5 years (to 2003). This agreement was contingent upon an ODP contribution of up to \$5.0 million in 1992 for capital investment and ship repairs needed by the vessel in order that it continue operations in an efficient manner. The opportunity to extend the contract for the *JOIDES Resolution* is of significant benefit to ODP, as the day rate of approximately \$45,000 is far cheaper than the cost of a comparable drillship at this time. Day rates for a *JOIDES*

Resolution class ship presently range from \$100-180K per day, depending on the area of operation. NSF has agreed to contribute the \$6 million necessary for dry dock activities, with the funding split equally between FY'98 and FY'99. In addition to the ship modifications, there are plans to enhance the capability of the scientific infrastructure on board the ship, and approximately \$300,000 have been budgeted in ODP's FY'99 plan to support these activities.

Ship Modifications

The costing of the workscope tasks can only be estimated at this time because, until bids for major pieces of new equipment are received, or until a given project is started and the equipment in question opened up, the actual costs are impossible to predict. Therefore, the costs assigned to the dry dock projects are conservative and have been projected at the high end of the spectrum. Because of this approach, the workscope exceeds the \$6 million budget that has been agreed to with ODL. Thus, only if some major projects turn out to be less expensive than forecast, will all of the projected workscope be achieved. Alternatively, if projects are as expensive as forecast, then lower priority tasks will not be undertaken. There is a contractual dry dock agreement in place with ODL that specifies the following: any overrun of the \$6 million budget will be shouldered by ODL; the workscope will be periodically reviewed by ODP as projects become better understood; any changes to the

Identified Dry Dock Projects with Cost Estimates:

New Automatic Station Keeping System	\$1,284,897
New Data Management System	915,428
Thrusters/Propulsion/Steering/Mooring	569,000
Environmental Equipment/Installation	50,000
Hull, Piping, and Shipboard Services	1,054,000
Drilling and Electrical Equipment	339,000
Classification	80,000
Lifesaving and Firefighting	110,000
Electrical Switchgear/Motors/Generators	154,000
Cranes	305,000
Shipyards Services and Supervision	540,000
Living Quarters	626,000
Radio Equipment	78,000
Lab Stack	21,000
Total	\$6,126,325

workscape proposed by ODL must be approved by ODP; and during dry dock ODP will have representatives from Drilling Services and Administration to provide technical and contractual oversight of the dry dock project. Moreover, in an effort to minimize the costs associated with dry dock activities, ODL will carry out as many workscope projects as possible utilizing the ship's crew prior to the dry dock.

Project priority will be given to ensuring the safety and seaworthiness of the vessel by adhering to the well-defined ABS requirements. Next in priority will be projects that focus on maintaining or improving the quality of the overall shipboard performance. Of high priority in this category is the replacement of the Automatic Station Keeping (ASK) system, and an upgrade of the thrusters and the Data Management System (DMS). In addition, maintenance of the *JOIDES Resolution's* drilling systems is required to ensure the continuation of current coring capabilities. Finally, of importance but lower priority, improvements to the living quarters will take the form of noise reduction measures, room upgrades, and improved ventilation and air conditioning.

- **Automatic Station Keeping (ASK)**

The ASK system is the brain of the dynamic positioning system, gathering signals from various sensors monitoring the position of the vessel and from sensors that measure the external forces working against the vessel which cause her to move off location (i.e., wind and current). The ASK system then sends orders to the thrusters and propulsion system so the vessel stays on location without being attached to the seabed. While the present system remains functional, it is obsolete by today's standards. In order to maximize our chances for reliable operations for another five years, it is important to replace the old unit with a new system that will be more reliable and will operate much more efficiently saving fuel and reducing wear on equipment.

- **Data Management System (DMS)**

The DMS monitors and controls the distribution of power to the vital pieces of equipment on the vessel (i.e., propulsion equipment, thrusters, drilling equipment, etc.). The *JOIDES Resolution* is equipped with a DMS that is obsolete by today's standards and is neither effective nor reliable. In order to ensure continued operation of the system and gain improved reliability for another five years, a new DMS will be required. A new DMS, used in conjunction with a new ASK system, will translate into much better reliability and in some situations improved fuel economy.

- **Thruster, Propulsion and Steering**

The 12 thrusters on the *JOIDES Resolution* are the units that, in conjunction with the main propulsion, allow the vessel to be dynamically positioned by being able to provide the necessary thrust in any direction. In order to maintain the ability to dynamically position the vessel, the thrusters must be thoroughly inspected and serviced to ensure their continued service.

- **Environmental Equipment/Installation**

The costs are associated with acquiring and installing environmentally compatible equipment required by regulations for vessels operating in environmentally sensitive areas (i.e. Antarctic). In this regard, a new garbage disposal system has been installed which exceeds environmental requirements for all marine operations.

- **Hull, Piping, and Shipboard Services**

The hull, associated tanks incorporated into the hull, and the pipework allowing for the transfer and flow of the various fluids throughout the vessel are main components of the vessel. The hull of the *JOIDES Resolution* is still in good condition after 20 years of service and, if properly maintained, another 15 to 20 years' life expectancy is reasonable. It is inevitable, however, that some corrosion will occur on various sections of the hull, tanks, and pipework. Various sections have been repaired as required over the years; however, it will be very important to thoroughly inspect, repair, and protect all sections of the vessel exposed to the elements so that further corrosion does not reduce the life of the vessel.

- **Drilling and Electrical Equipment**

The equipment directly associated with the drilling function will be inspected, serviced, and maintained as required to ensure that it will be functional for another five-year contract. The electrical equipment requiring servicing will be the majority of the large electrical motors and the generators.

- **Cranes**

The vessel has three cranes that will be 20 years old and require servicing, repair, and replacement of various components to ensure that they can continue to be operated safely.

- **Shipyard Services**

These costs are associated with utilizing the services of the shipyard that are not directly associated with any one project but are associated with all of the work performed. It is also the cost of additional supervision and engineering that will be required to ensure that the project is performed properly.

- **Living Quarters**

Improvement to the living quarters will con-

centrate on noise reduction, room upgrades, improvement/replacement of the ventilation and air conditioning systems, and replacement of the fire detection system.

Science Modifications

ODP is responsible for all laboratory stack maintenance and modifications, and the Program has set aside \$309,042 in its FY'99 budget for this purpose. Until the bid packages are in and reviewed and the costs for each project defined, it is not clear which of the tasks on this list will be implemented. ODP's Marine Laboratory Technicians will be carrying out as many projects as possible during the dry dock and associated transits under the project management of a Laboratory Officer. The following lab stack projects have been proposed by Science Services:

- Refurbish the sonar dome and replace the defective 12-kHz transducer;
- Maintenance of aft transducer;
- Creation of access to the lab stack foundation to allow visual inspection and possible foundation bolt replacement to the lab stack. The access panels will also allow for future foundation strengthening;
- Installation of a riser hold lift to increase the speed, efficiency, and safety of loading and unloading core and other materials from the riser hold;
- Modification of the core laboratory to increase the speed and efficiency of core processing in the core lab and to provide adequate ventilation allowing for the safe degassing of potentially hazardous cores in the core lab;
- Blasting and repainting the fantail winch;
- Fume hood replacement in the chemistry laboratory;

- New cabinets and countertops in the chemistry laboratory;
- Conversion of the second core reefer, currently used to store supplies including chemicals, batteries, and photographic supplies, back to a core-only storage area. Alternative storage for the chemicals can be arranged in the second look lab. The photoshop requires roughly 130 cubic feet of refrigerated storage, which can be supplied by the acquisition of two refrigeration cabinets housed in the second look lab;
- Refurbish the Sea Horse hydraulic motors for the seismic streamers;
- Removal of the Doppler sonar;
- Addition of mezzanine decks in the riser hold;
- Reconfiguration of the riser hold mezzanine decks to increase and centralize storage areas on the *JOIDES Resolution*. All mezzanine decks would be directly accessible by the riser hold lift, thereby minimizing the manhandling of science supplies and cores by the Marine Laboratory Technicians;
- Installation of a microbiology laboratory with two options under investigation: microbiology van; lab stack addition of an eighth floor.

The bid packages for the ship and science modifications are in the final stages of preparation and will be sent out to prospective dry dock operators in a few weeks time. The dry dock selection will be depending on those responses. Based on the ship's sphere of operations in FY99, we can be sure that the dry dock will be located in the western Pacific and we estimate that the ship will be in the yard for 40-45 days. An additional time period of one to two weeks will be required for sea trials. ❖

Leg 176 – Continued from page 14

spreading Mesozoic ridge: Example of the Montgenèvre ophiolite, western Alps. *In: Vissers, R.L.M., and Nicolas, A. (Eds), Mantle and Lower Crust Exposed in Oceanic Ridges and in Ophiolites: Dordrecht (Kluwer Academic Publishers), 123-145.*

Dick, H.J.B., Meyer, P.S., Bloomer, S., Kirby, S., Stakes, D., and Mawer, C., 1991a. Lithostratigraphic evolution of an *in-situ* section of oceanic layer 3. *In: Von Herzen, R.P., Robinson, P.T., et al. (Eds). Proc. ODP, Sci. Results 118: College Station, TX (Ocean Drilling Program), 439-538.*

Dick, H.J.B., Schouten, H., Meyer, P.S., Gallo, D.G., Bergh, H., Tyce, R., Patriat, P., Johnson, K.T.M., Snow, J., and Fisher, A., 1991b. Tectonic evolution of the Atlantis II Fracture Zone. *In: Von Herzen, R.P., Robinson, P.T., et al. (Eds). Proc. ODP, Sci. Results 118: College Station, TX (Ocean Drilling Program).*

Hopkinson, L., and Roberts, S., 1995. Ridge axis deformation and coeval melt migration within layer 3 gabbros: evidence from the Lizard Complex. *U.K. Contrib. Mineral. Petrol.*, 121:126-138.

Marsh, B.D., 1995. Solidification fronts and magmatic evolution. *Mineral. Mag.*, 60: 5-40.

Pallister, J.S., and Hopson, C.A, 1981. Samail ophiolite plutonic section: field relations, phase variations, and a model of a spreading ridge magma chamber. *J. Geophys. Res.*, 86: 2593- 2644.

Robinson, P.T., Von Herzen, R.P., et al., 1989. *Proc. ODP, Init. Repts*, 118: College Station, TX (Ocean Drilling Program).

Swift, S., Hoskins, H., and Stephen, R., 1991. Seismic stratigraphy in a transverse ridge, Atlantis II Fracture Zone. *In: Von Herzen, R.P., Robinson, P.T., et al. (Eds). Proc. ODP, Sci. Results 118: College Station, TX (Ocean Drilling Program), 219-226.* ❖

Riser Drilling Technology for an Integrated Ocean Drilling Program (IODP)

by **Shinichi Takagawa (JAMSTEC)**

The Japan Marine Science and Technology Center (JAMSTEC) has been studying Riser Drilling Technology under the name of OD-21 (Ocean Drilling in the 21st Century) since 1990. The objective of this program is to develop a riser drilling vessel system for geoscientific research. Such a ship would contribute to the international science community by allowing drilling in environments that cannot be drilled with the present vessel, the *JOIDES Resolution*, (such as through hydrocarbon-rich layers), as well as deep drilling, with one ultimate goal being an intact section of oceanic crust to and beyond the "Moho". This riser drillship would be one of the vessels in a two-ship program envisaged for scientific ocean drilling beyond 2003 in the 1996 Long Range Plan of the Ocean Drilling Program. The second vessel would likely be a *JOIDES Resolution* type non-riser drilling vessel. Planning for this new program, currently referred to as the Integrated Ocean Drilling Program (IODP), is underway.

The Riser Drilling Operation

Riser drilling is a standard method used in the offshore oil industries, where it is also known as "Mud-Circulation Drilling". In the very early age of industrial oil drilling, water was used as the circulating fluid during drilling. However, hole stability was a common problem during such operations. The addition of mud to the fluid being circulated proved to be helpful in this regard as well as having other advantages.

Figure 1 shows a schematic mud-circulation system. While the drill string is rotated, mud is pumped down through the drill pipe to the bottom of the hole. It cools, cleans, and lubricates the bit, and then entrains the cuttings. The latter is very important to avoid the drill string becoming stuck and thus preventing it from rotating and drilling. One important advantage of mud is that its viscosity and density are both greater than water, and hence the pressure the fluid exerts, and the effectiveness of removing cuttings, are substantially improved. The pressure of the mud against the walls, as well as the build-up of mud cake against the wall surfaces as water is forced into the formation, helps stabilize the hole. The mud with entrained cuttings returns to the ship by flowing up between the drillpipe and the "riser" — a pipe that surrounds the drillpipe. The cuttings are separated from the mud and both can then be analyzed: The cuttings provide information on the type of the formation

being drilled and substitute for core data when the core is not recovered. Analysis of mud, so-called "Mud Logging", is very important for detection of oil and gas. The mud, which is extremely expensive, can then be reused.

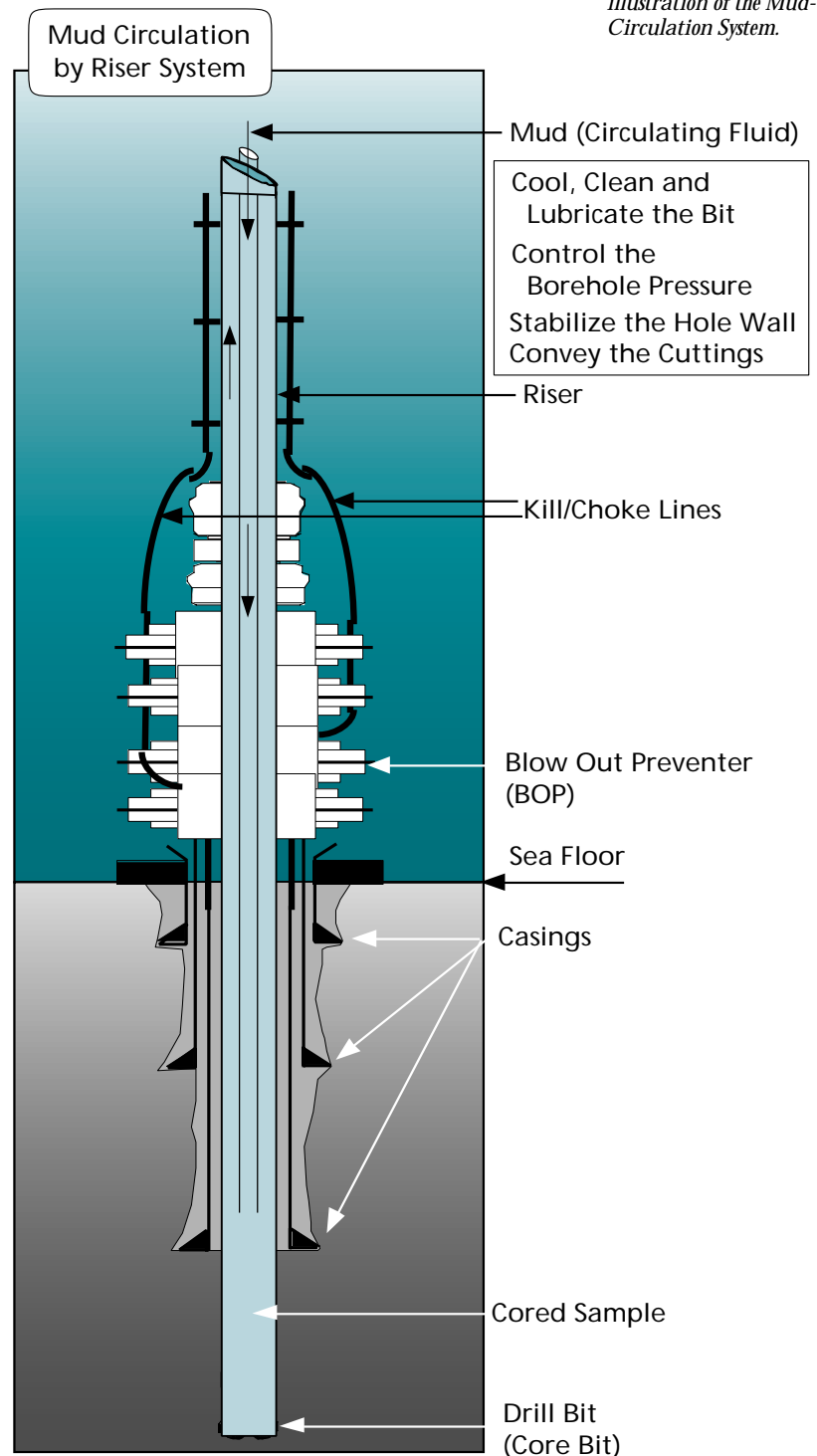

Figure 1: Schematic illustration of the Mud-Circulation System.

However, one potential problem is that fluids from the drilled formation entering the hole can flow up the hole to the vessel. This can cause extremely dangerous situations, especially when drilling into gas reservoirs because of its rapid expansion as it flows upward. The upward flow of mud can be interrupted by activation of a safety system, the "Blow-Out Preventer" (BOP), if flow of formation fluid into the hole is detected from the change in the flow rate of the returning mud. The fact that formation fluid enters the hole means that the hydrostatic mud pressure is lower than the formation pore pressure. Pumping denser mud prevents further formation fluid from entering the hole. A "Choke Line" is subsequently used to discharge the formation fluid from the hole.

Once a hole, or a section of a hole is logged, further stabilization is achieved by cementation of a casing string in the hole which is usually solid but can be perforated depending on the scientific objectives of the hole. Continuous drilling and casing thus results in a hole whose diameter successively decreases (Fig. 2). The goal is to complete a deep hole with casing that is then suitable for deployment of various monitoring units for long-term observation studies.

Targeted Capabilities of the OD-21 Program

Mud circulation drilling is the key technology for deep penetration and drilling through oil/gas layers. At present, the oil industry uses riser drilling to achieve penetration depths of several km below the sea floor. However, there are some limitations

that need to be overcome over the next few years in order to use the riser system for scientific drilling. One of the main difficulties with riser technology is the amount of time that is required for deployment and retrieval. Depending on the water depth, the recovery usually requires 2 or 3 days of operations. The onset of any severe weather during this time may result in the full length of the riser having to be suspended in the water — a situation referred to as a "Riser Hang-Off". During this time, the suspended riser behaves like a string, and in the case of resonance between the string's and the vessel's motion, a catastrophic break of the riser can occur. This is a very serious operational scenario that potentially limits the water depth a riser can be operated. Hence, ways of strengthening the riser in order to expand operational sea conditions is an important technological effort.

Conventional riser drilling have been conducted by the offshore oil industry primarily in maximum water depths of ~1500 m, although the current record is in water depths of 2328 m. Recently, the offshore oil industry has become interested in riser drilling in water depths of ~2100-2300 m, and they have initiated the construction of new drill ships for this purpose. However, their main operation area, the Gulf of Mexico, is characterized by moderate weather conditions implying a relatively low risk of "Riser Hang-Off" situations.

OD-21, on the other hand, requires a riser drilling vessel capable of both operations worldwide (with exception of ice-covered areas), and an operational water depth of approximately 4000 m.

Figure 2: Schematic diagram of the Standard Casing Program.

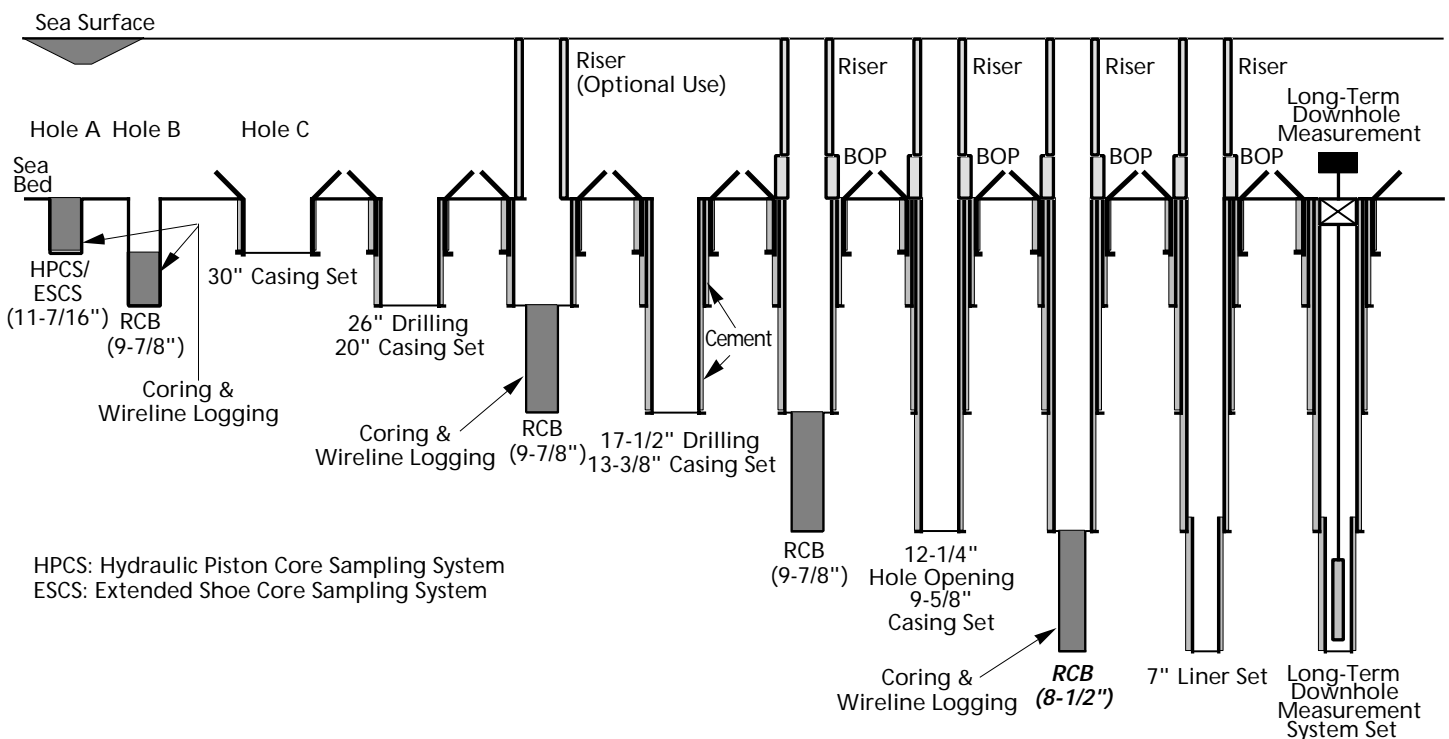

Riser drilling in 4000 m water depth is a very ambitious target and requires a high level of technological and operational experience in deep drilling. Thus, the initial stage of OD-21 calls for the development of a riser system to be operated in 2500 m water depth. Long-term planning will focus on further development of the system for operations in 4000 m water depth based on the data and experience obtained from operations of the 2500 m riser system.

Planning continues both in terms of science and technology. The JOIDES Technology and Engineering Development Committee (TEDCOM), JAMSTEC and ORI (Ocean Research Institute, University of Tokyo) jointly held a conference named "International Workshop on Riser Technology" at Yokohama, Japan, in 1996. Equal numbers of representatives from science and technology discussed the application of the riser technology to scientific targets requiring deep drilling (JOIDES-TEDCOM, et al. 1997, Larsen & Kushiro 1997). CONCORD (CONFERENCE on Cooperative Ocean Riser Drilling) was the second conference on this topic, organized by JOIDES, JAMSTEC, and ORI and held in Tokyo, Japan, in 1997. The general consensus of the conference was that the riser drilling program will open up a new and exciting phase of scientific exploration, with consequent societal and economic benefits. The development of a riser drillship for scientific use was considered indispensable for improving our understanding of the dynamic processes that shape the planet, control the distribution of resources, and shape our environment through earthquakes, volcanism and climate change. Direct observations of major earthquake events through long-term monitoring was considered a high priority for the new drilling program to start at the beginning of the 21st century (JOIDES et al., 1997; Humphris 1997).

Taking into account the requirements and recommendations identified during these conferences, JAMSTEC has been proceeding with a preliminary riser drillship design (Fig. 3), with the goal of building and completing the vessel for operations in waters depths of up to 2,500 m by the year 2003. The integration of the *JOIDES Resolution*, or its successor, for ODP-type operations with a riser drillship for deep penetration (~7km) in a unique and effective program of ocean drilling is expected to reveal fundamental insights into the earth's environment and earth's interior. Inter-governmental discussions and planning efforts within the international science communi-

ties now focus on how to materialize the "Integrated Ocean Drilling Program" — the new and technically advanced program for scientific ocean drilling to follow ODP beyond 2003.

REFERENCES

Humphris, S. 1997. Recommendations from the CONFERENCE on Cooperative Ocean Riser Drilling (CONCORD). *JOIDES Journal*, 23 (2): 27.

JOI, 1996. Ocean Drilling Program Long Range Plan — Understanding our Dynamic Earth through Ocean Drilling, March 1996, Joint Oceanographic Institutions, Inc.

JOIDES, JAMSTEC, ORI, 1997. Conference on Cooperative Ocean Riser Drilling (CONCORD) Report, July 1997, Tokyo, Japan.

JOIDES-TEDCOM, JAMSTEC, ORI, 1996. Proceedings of "International Workshop on Riser Technology", October 1996, Yokohama, Japan.

Larsen, C. & Kushiro, I. 1997. OD-21 — Ocean Drilling in the 21st Century. *JOIDES Journal*, 23 (1): 28-29. ❖

Figure 3: Artist's Drawing of the OD-21 Riser Drillship.

Tentative Principal Particulars of the New OD21 Vessel

Length Over All:	ab. 190.0m
Breadth Molded:	32.0m
Depth Molded:	13.0m
Gross Tonnage:	ab. 31,000mt
Accommodation:	150
Riser Length:	2,500m(Init.) 4,000m(Fin.)
Drill String:	10,000m(Init.) 12,000m(Fin.)

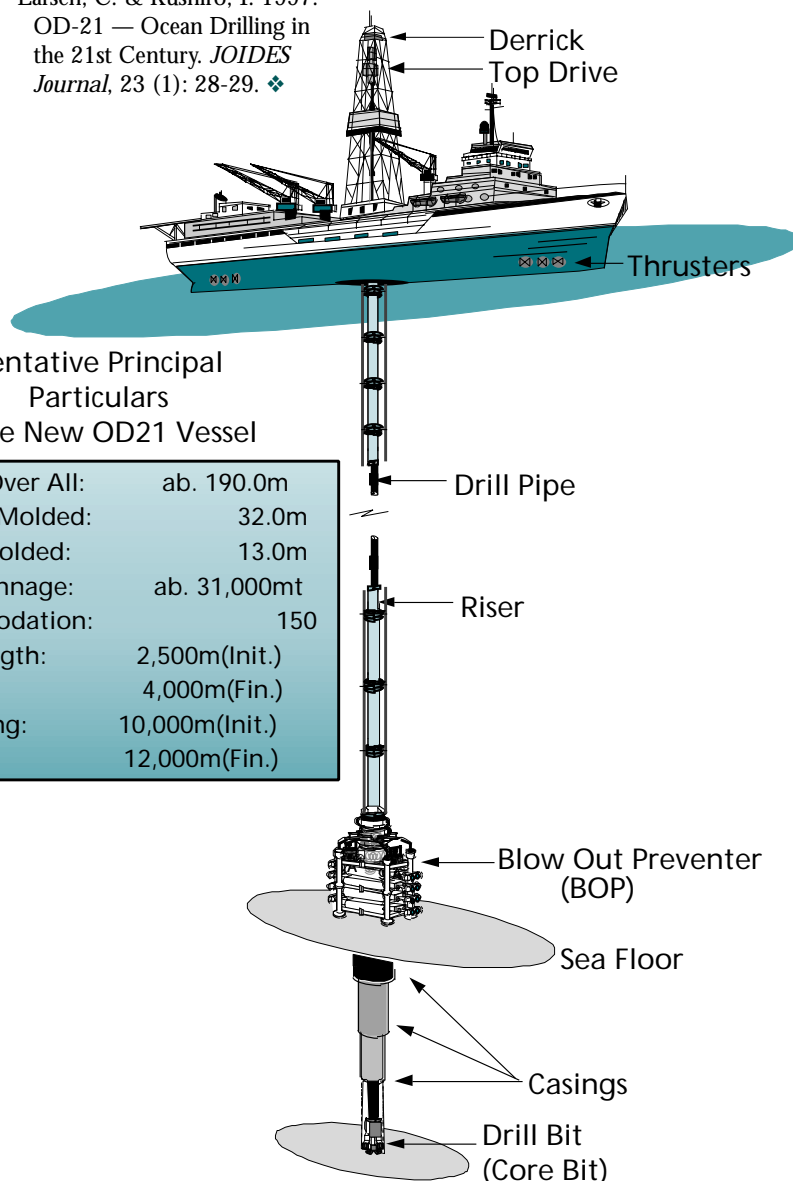

In keeping with ODP's commitment to actively seek collaboration and communication with other global geoscience initiatives, the JOIDES Journal is highlighting in each issue one or two of these programs in order to inform the ODP community of their goals and objectives.



Focus on International Geoscience Initiatives

PAGES: Past Global Changes

by *Keith Alverson*

PAGES is the International Geosphere Biosphere Program (IGBP) concerned with recording and understanding past climatic and environmental changes. Some of the key questions driving PAGES science include:

- What are the temporal and spatial patterns of climate variations?
- What are the causes of this climate variability?
- How does climatic change affect environmental systems?
- How do climate and environmental change affect humans and their infrastructural device?

These questions are often asked in the context of the last few decades since instrumental recording of global climate data. On climatic timescales, by definition longer than these few last decades, they are often addressed in the context of future climate prediction scenarios using numerical models. There is, however an important additional context for which these questions form the backbone of scientific research, the long-term record of the environmental history of the Earth. The Earth's climate history has been long, amazingly complex, and marked by enormous changes. By reconstructing and understanding this historical climate record, we can gain a better understanding of the mechanisms controlling the Earth's climate system, and perhaps, together with insights obtained from numerical modeling exercises, anticipate how it might respond to future perturbations.

As an organizational body, through its newsletter, publications, database development and sponsoring of workshops, PAGES fosters efforts to synthesize the myriad of disparate paleoclimatic efforts across multiple disciplines and nations. The overall goals are simply to provide a freely accessible record of and, more importantly, a detailed understanding of past changes in the Earth's climatic and environmental systems.

The "Time Streams" and PEP Transects

One question which naturally arises is how far back in the past we need to look in order to obtain

a reasonable understanding of climate variability, thereby improving our chances of estimating how it may affect us over the next few decades. The answer to this question is not clear-cut. The PAGES perspective is that the time frame should be sufficient to allow reconstructions of climate or environmental changes which are:

- relevant to an understanding of the present day climate system and its broader environmental implications;
- representative of the full range of variability of the climate in the geologically recent period;
 - quantifiable, with specified uncertainties;
 - available at high temporal resolution.

The first criterion immediately rules out the very distant past; for example, when continental configurations were markedly different from today's. The second, although difficult to assess, requires at a minimum that the past two glacial cycles, or roughly the past 200,000 years, are included. This time period represents PAGES 'time stream two'. Relevant time series over this period include the ice core records from Greenland (GRIP/GISP) and Antarctica (Vostok), marine sediment records, some lake sediment records (Lake Baikal) and loess-paleosol sequences from China. Usually, such long time series are available, at best, at decadal to century scale resolution, though there is a growing need for higher resolution analyses over key periods of rapid transition.

The latter two conditions are the most difficult to come to grips with, in part due to the incredible diversity of paleorecords. They come closest to being achieved within PAGES 'time stream one', roughly encompassing the past two millennia. Records from this shorter time stream are sought at annual or higher resolution. Proxies from which climatic data are available at this resolution include polar and tropical ice cores, banded corals, varved marine and lake sediments, tree rings and documentary records.

Some of the most interesting records on both PAGES time streams come from marine sediment



cores. The records of ice-rafted debris in the North Atlantic which distinguish Heinrich layers and Dansgaard-Oeschger events are an obvious example. Another is the record from the Santa Barbara Basin showing periods of anoxia and ventilation which match the Greenland ice core temperature record with a synchronicity demonstrating the operation of as yet imperfectly understood teleconnection mechanisms.

One of the most promising new priorities for marine coring reflects the need to link the marine record to the PAGES continental Pole-Equator-Pole (PEP) transects in order to elucidate the roles that the oceans and atmosphere play in establishing the inter-hemispheric, and marine-continental patterns of climate change. High resolution, high quality marine records are a vital cornerstone for much of the research that PAGES, and its shared marine program IMAGES, envision for the coming decade. To that end, PAGES sees the efforts to plan for the continuation of ocean drilling, after the culmination of the current ODP program in 2003, as a vital part of the multi-national, multi-proxy effort to unravel the complexities of the Earth's climate system and its impacts on both marine and terrestrial ecosystems.

The Data Synthesis

It is easy to get lost in the maze of different proxy records and the intricacies in extracting climatic information from them. Overlying them all, some of the key messages from PAGES science include:

- Climate change has shown both broad scale spatial coherence as well as highly differentiated regional expression.
- Even during the Holocene period, the natural climate system has varied locally and globally over a far greater range than can be inferred from instrumental records.
- Dramatic climatic shifts have occurred very rapidly in the past, probably including global average temperature changes of several degrees C on timescales of less than a decade; for example during the termination of the Younger Dryas cold event.
- Although shifts in past climate can be found that are larger and faster than those predicted as a consequence of anthropogenic greenhouse

warming, the rate of increase in greenhouse gases themselves, as well as the rate of ecosystem change in many areas of the globe, are unprecedented within PAGES time stream paleorecords.

- The paleorecord is rich in examples of the interactive nature of the relationship between human societies and their impact on the environment.

With about a decade of existence behind it, PAGES is one of the more 'mature' of the IGBP core projects. Nonetheless, many areas of PAGES science are only now poised at the cusp of what promises to be extremely rewarding scientific endeavor. One example is the joint initiative with the World Climate Research Program Climate Variability and Predictability Programme (WCRP – CLIVAR) concentrating on producing global, annual resolution, high accuracy records of the climate variability of the last millenium. Another example is the new PAGES effort to unravel human influences and the ecosystem and environmental response.

Although new and exciting science directions such as these will continue to be pursued, PAGES is attempting over the next two years to produce a synthesis of the work completed by the research community it seeks to serve and coordinate. The synthesis process has only just begun and we are actively seeking input from the worldwide paleoscience community. To that end, we have established an electronic forum on our website to facilitate rapid dissemination and discussion of ideas for the synthesis effort. The substance of this synthesis is still very much open, other than its physical manifestation as a book in the IGBP Cambridge University Press series. We look forward to a profitable discussion amongst the paleoclimate community as the synthesis develops. ❖

Information:

For detailed information about the PAGES program please contact the International Project Office:

PAGES IPO,
Bärenplatz 2,
3011 Bern, Switzerland
E-mail: pages@pages.unibe.ch
Internet: <http://www.pages.unibe.ch/>

A Message from the Chair —

It gives me great pleasure to welcome Dr. Kathryn Moran as the new Director of ODP at JOI. Kate brings an in-depth knowledge of the Program, having been deeply involved in ODP for many years, both as an active researcher and in various roles within the JOIDES Advisory Structure. Most recently, she acted as Chair of the JOI Steering Committee that provided advice on the implementation of the Janus database. In addition, Kate brings a great deal of experience with the off-shore geotechnical industry, which will be invaluable as ODP moves forward in establishing collaborations with the commercial sector — a direction that many of us view as holding much potential for the future of the Program.

As of the summer SCICOM and OPCOM meetings, the new JOIDES Advisory Structure completed a full annual cycle of activities beyond the six-month transition from the old structure. The Panel Chairs discussed the new system at their annual meeting, and there was general agreement that, overall, the system of proposal review and the furnishing of advice to SCICOM seems to be working quite well. In particular, the Science Steering and Evaluation Panels felt that the inclusion of external evaluations was a valuable addition to the Program. So — thanks to all of you who have provided us with advice through that mechanism, and I hope that you will continue to participate in this important process! That is not to say that there are no problems that need to be ironed out! The Panel Chairs have identified some issues related to the annual calendar that need adjusting, together with some areas in need of clarification and better definition. We are striving to sort these out to ensure that we provide well-considered, timely, and thoughtful advice to JOI.

Before the end of the year, a new Guide to the Ocean Drilling Program will be published. This has taken longer to produce than we hoped because many ODP policies required revision over the last year as the Advisory Structure changed and as the process of renewal for Phase III of the Program proceeded. For example, as explained in the following article by Bob Detrick, the Program has now defined a series of ODP membership levels that we hope will encourage participation by more countries and consortia. In addition, the Scientific Measurements Panel, in conjunction with JOI and

ODP-TAMU, have integrated the Sampling and Publications Policies to provide a clearer explanation of the links between the two, and the responsibilities of participating scientists. Although by nature the Guide to ODP is a document in need of almost continuous revision, we hope that you will find it comprehensive and helpful.

In my last letter, I reported on the steps being taken to begin the planning process for the drilling program to succeed ODP. We have made some important progress on three fronts over the last six months. First, I should thank every one of you who sent in a Letter of Interest in response to our request for input for the conference to be held next spring on the scientific objectives of a future drilling program. As I write this on the deadline for those letters, we have received over 200 responses from the international community. This excellent response I take to be a reflection of the overwhelming interest

in seeing drilling continue to play a major role in our research activities. The Conference Organizing Group is currently using the Letters of Interest to determine the structure of the conference that will take place on 26-29 May in Vancouver, B.C.

The second area of progress has been in setting up a Detailed Planning Group (DPG) to begin planning for the first project at a Seismogenic Zone using a riser drilling ship. Based again on Letters of Interest, SCICOM selected individuals to add to the core group of a DPG at the August meeting. This DPG is now constituted, and ready to begin the planning process.

The third area of activity has been in setting up an international workshop on 17-18 November in Houston, Texas to obtain some guidance from industry representatives on the infrastructure and operational issues that need to be considered in a program operating two major drilling vessels (as well as possible other platforms) on a global basis. Our current Advisory Structure is not well-equipped to identify these issues, and so we are hoping that colleagues from industry can provide us with some direction to allow us to better define the necessary planning process. One thing is clear — as we move towards a two-ship program, the planning activity will become more complex and more time-consuming. Although this planning must be done under the umbrella of the JOIDES Advisory Structure, it will no doubt require the dedicated efforts



of a group of people to ensure that all scientific, technical, and management avenues of planning proceed hand-in-hand and in a timely fashion.

This JOIDES Journal and the accompanying ODP Directory are the last to come from the JOIDES Office in Woods Hole, as the Office will move to GEOMAR in Germany as of 1 January 1999. It has been our pleasure to work with you all, and I especially thank the members of all the Panels, Committees, and Planning Groups for their willingness to devote their time and efforts to

ODP, and to struggle with us through the reorganization of the Advisory Structure! We are delighted that we are passing the Office on to such capable hands as those of Bill Hay and his team — and wish them every success over the next two years!

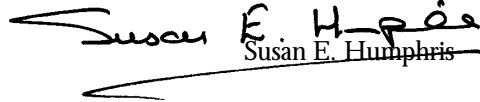

Susan E. Humphris

EXCOM Adopts New Policy on Associate Membership

At its June meeting in Bonn, Germany, the JOIDES Executive Committee adopted a new policy on Associate Membership. Associate Membership was originally approved by EXCOM and ODP Council in July 1995, primarily as a means of expanding membership in ODP to include countries that have a strong interest in scientific ocean drilling, but cannot join at the full membership level. Recent changes in the organization of the JOIDES Advisory Structure and the level of participation of former Full Members precipitated the policy changes adopted by EXCOM in Bonn.

Three levels of Associate Membership were defined, at levels of 1/6 (Associate 1), 1/2 (Associate 2), and 2/3 (Associate 3) of a Full Member contribution (currently set at ~\$3 M/yr). Shipboard participation will be directly proportional to a member's contribution, but *only* Full Members of ODP (whether individual countries or consortia) will have voting rights on the two policy and scientific decision making bodies in the JOIDES structure, EXCOM and SCICOM. For the purposes of defining Associate Member levels, the standing Panels and Committees within the JOIDES Advisory Structure were divided into three groups: Group I (EXCOM and SCICOM), Group II (ESSEP and ISSEP) which provide scientific advice, and Group III (SCIMP, SSP, TEDCOM, and PPSP) which provide technical and operational advice. An Associate-1 member is entitled to one member on one panel from both Group II and Group III, while an Associate-2 member will have representation on two panels from Group III and on one panel from Group II. Members at the Associate-3 level will have membership on all Group II and III panels, but not on SCICOM or EXCOM. Countries and consortia at all levels have the right to observer status on all JOIDES panels and committees, and can participate in discussions at the discretion of the Chair. In June, ODP welcomed the Peoples Republic of China as its first Associate Member. They will be participating at the 1/6 level as an Associate 1 member.

Although full and equal participation of members in ODP remains the goal of the program, EXCOM recognized that sometimes, often for reasons beyond the control of a particular member, this has not always been possible. EXCOM therefore also adopted a policy for Full Members in the past who reduce their contribution below the full subscription level (EXCOM Motion 98-2-8). In this case, shipboard participation will be immediately reduced proportionately. They will retain full participation on JOIDES Advisory Panels provided their contribution is equal to, or greater than, 5/6 of a Full Member, and they make a firm commitment towards returning to full membership and are making significant progress towards this goal. EXCOM will review the status of these members annually. If these conditions are not met, the member will become an Associate Member at the appropriate level and will participate in JOIDES Advisory Panels as described above. Under this policy, we expect France will become an Associate-3 member beginning in 1999.

EXCOM hopes that this new Associate Membership policy will encourage greater participation in ODP and will provide a flexible but fair framework within which to deal with changing circumstances in member countries and consortia.

Bob Detrick
EXCOM Chair

The FY'00 ODP Science Plan: Legs 188-193

Susan E. Humphris

The development of the FY'00 schedule began in August 1997 when SCICOM scheduled Leg 187 (Australia-Antarctic Discordance) and tentatively penciled in Prydz Bay as the second in a series of legs aimed at Antarctic Glacial History as Leg 188. This process continued at the August 1998 SCICOM and OPCOM meetings, when plans for Leg 188 were reviewed, and additional Legs were added to extend the schedule through FY'00 and into the first part of FY'01. Two legs will be drilled that address high priority Southern Ocean objectives within the ODP Long Range Plan core theme, Dynamics of Earth's Environment: Leg 188 (Antarctic Glacial History — Prydz Bay) and Leg 189 (the Southern Gateway between Australia and Antarctica). Within the other ODP Long Range Plan core theme, Dynamics of Earth's Interior, Legs 192 (PACMANUS Hydrothermal System) and Leg 193 (History and Evolution of Ontong-Java Plateau) address objectives within the sub-theme, Exploring the Transfer of Heat and Materials from the Earth's Interior; Leg 190 (Nankai Trough Prism) focuses on deformation and fluid processes at convergent margins, which falls under the sub-theme Investigating Deformation of the Lithosphere and Earthquake Processes; and Leg 191 (West Pacific Seismic Network) tackles objectives under the ODP Long Range Plan Initiative, In-Situ Monitoring of Geological Processes.

Leg 188: Antarctic Glacial History — Prydz Bay

The Antarctic ice sheet is a key component of the world's climatic system and has a major influence on global sea levels. At present, knowledge of the history of the Antarctic ice sheet is fragmentary making it impossible to predict whether the present ice sheet will grow or diminish with global warming. A precise date for the onset of Antarctic glaciation has not yet been determined, and there is much controversy over the stability of the East Antarctic ice sheet, particularly during the Pliocene. In order to gain a better understanding of the role of the Antarctic ice sheet in global climate change and to test models of ice sheet behavior, ODP plans to conduct a series of Antarctic drilling legs.

The first of these, Leg 178, drilled on the margin of the Western Antarctic Peninsula in spring 1998 (Barker et al., this issue). The Science Steering and Evaluation Panel for Earth's Environment (ESSEP) and SCICOM assessed the results of this Leg in order to evaluate the success of the overall

strategy of drilling progradational wedges and sediment drifts planned as the basis of the other Antarctic drilling legs. With some revisions based on the experiences of Leg 178, SCICOM recommended that a second leg be scheduled.

Leg 188 will drill Cenozoic sedimentary sequences in Prydz Bay, Antarctica, and on the adjacent continental slope and rise, known as the Cooperation Sea, to (1) link events in the East Antarctic Ice Sheet with changes in the Southern Ocean; (2) recover a record of Plio-Pleistocene ice advances and interglacial deposits from the Antarctic continental slope; (3) date the earliest evidence of glacial activity in Prydz Bay; and (4) obtain information about the Paleogene environment of Antarctica. This Leg will require an ice support vessel, and SCICOM has stipulated that it will proceed only if affordable ice support can be acquired. The results of Leg 188 will complement the Cape Roberts Project, a joint venture involving scientists from Germany, Italy, New Zealand, the UK and the US, which seeks to recover cores from a 1500 m thick sedimentary sequence off Cape Roberts in the southwestern Ross Sea.

Leg 189: Southern Gateway between Australia and Antarctica

A major feature that marks the Cenozoic Era is progressive cooling at high latitudes. This led to the development of the polar cryosphere, initially on Antarctica and later in the northern hemisphere. It has been proposed that climatic cooling and cryospheric development resulted from plate tectonic changes that progressively thermally isolated the Antarctic continent as the Circumpolar Current developed. The development of Circumpolar circulation resulted from the opening of the Tasmanian Seaway south of Tasmania in the Paleogene and the Drake Passage in the late Paleogene to early Neogene. Circumpolar circulation continued to expand during the Cenozoic with northward migration of Australia and expansion of the Drake Passage. These paleoceanographic changes likely played a fundamental role in the development of Cenozoic climate evolution, associated paleoenvironmental changes such as sea level, and in terrestrial and biotic evolution.

Early ocean drilling in the Tasmanian Seaway (DSDP Leg 29, 25 years ago) provided a basic framework of paleoenvironmental changes associated with the opening of the Tasmanian Seaway. Yet, the information obtained is of insufficient quality and resolution to fully test the hypothesis of

potential relations between the development of plate tectonics, Circumpolar circulation and global climate.

Leg 189 will target a suite of new sites designed to provide a quantum jump in the understanding of Circumpolar oceanographic and climatic evolution. For example, the relatively shallow region off Tasmania is one of the few places where well preserved and almost complete marine Middle Eocene to Recent carbonate-rich sequences can be drilled at present-day latitudes of 40°-50°S, and paleo-latitudes of up to 70°S. The drilling program will document the paleoceanographic and paleoclimatic changes associated with the Paleogene marine rifting history and Neogene drifting history of this key southern area.

Leg 190: Nankai Trough

Accretionary prisms represent unique and accessible natural laboratories for exploring the complex interplay of deformational, diagenetic, and hydrologic processes in initial mountain building processes. Some of the key questions relate to the distribution of deformation throughout an accretionary prism, the controls on what material is accreted and what is subducted, and the role of fluids and fluid flow in deformation in the prism. The Nankai Trough has been designated as the type example of a convergent margin accreting a thick section of clastic sediments. With unparalleled seismic resolution and structural simplicity, and data from three previous DSDP/ODP drilling legs, the Nankai accretionary prism is ideal for the development of rig-

orous mechanical and hydrologic models of fluid-linked diagenetic and tectonic processes in the rapidly deforming accretionary wedge.

Leg 190 will be the first in a two-leg program focused at the Nankai Trough. The first leg will consist of drilling and coring at three primary sites to compare two parts of the Nankai Trough with different wedge tapers and structural geometries. This will be followed by a second leg of logging-while-drilling (LWD) at four sites, and the emplacement of CORKs at three of these sites. Downhole monitoring by instrument packages sealed with CORKs should provide a continuous long-term record of fluid pressure and temperature, and the option of subsequent fluid sampling and permeability determinations with a submersible. This plan is dependent on the development of a new generation of CORKs that will allow multiple horizons to be hydrologically isolated and monitored. SCICOM has stated that the scheduling of the second Leg in the following year is contingent upon the successful development of the new CORKs. Other contingencies include: successful drilling and station-keeping in the current conditions encountered; evaluation by the JOIDES Advisory Structure (SSEPs, SCIMP and SCICOM) of the detailed scientific plans of the second leg; and identification of funds to reduce the cost to ODP of the whole Nankai program.

Leg 191: West Pacific Seismic Network

The International Ocean Network (ION) was officially founded in 1993 in recognition by the

ODP SCIENCE PLAN
Legs 188-192 (FY 2000) and
Leg 193 (FY 2001)

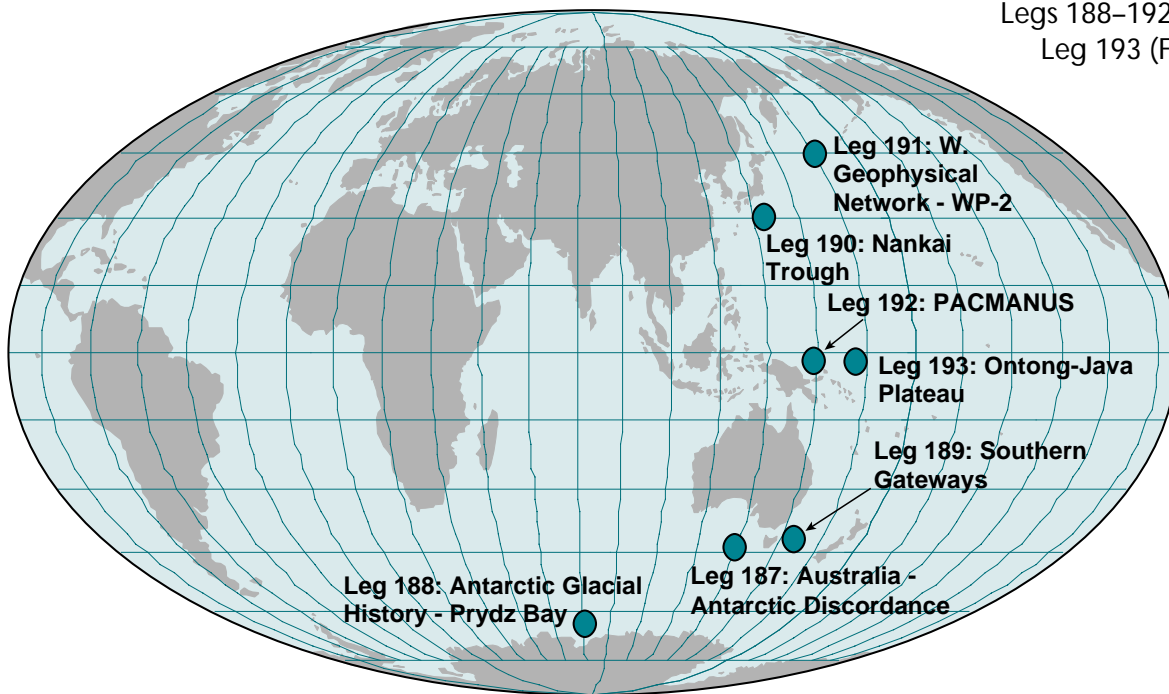

geoscience community that there is a critical need for permanent observatories in the deep ocean to fulfill two major scientific goals:

- (1) a uniform coverage of global terrestrial processes; and
- (2) long-term monitoring of active processes.

One of the first activities of ION was to develop a map of the coverage provided by existing seismic stations and to identify the squares (2000 km x 2000 km) with no permanent stations. They represent oceanic areas with no island sites that can be used for installation of observatories. Among the 20 squares, ION identified a priority list of 6 sites that (i) most meet the goals of the scientific program by improving the global coverage, and/or (ii) allow better monitoring of subduction zones in the W. Pacific.

The Western Pacific area is the best suited region on earth to address the dynamics of the subducting plates, formation and evolution of island arcs and marginal seas, and their relation to mantle convection. Regional geophysical network has been expanding in the land area over the years constituting one of the most densely stationed networks over Japan and to a lesser extent in eastern Asia. Leg 191 will drill a site in the Western Pacific (WP-2) that is located to provide a downhole seismometer installation in one of the high priority areas identified by ION. In addition, it will also provide unique seismic observations on the seawater side of the Japan Trench. Installation of the broadband seismometer is expected to be carried out using the Japanese ROV Kaiko.

Leg 192: PACMANUS Hydrothermal System

A long-standing objective of ODP has been to drill active hydrothermal systems in order to understand the nature of subsurface water-rock reactions, and to determine the three-dimensional architecture and hydrologic characteristics of hydrothermal deposits and their host rocks. Such knowledge is vital to developing rigorous concepts about the genesis of massive sulfide deposits and associated ores in ancient marine sequences, and thereby creating a new science base for mineral exploration on the continents. Important scientific objectives have already been met by Legs 106 and Leg 158 in volcanic-hosted deposits on the Mid-Atlantic Ridge, and Legs 138 and 169 in sediment-hosted deposits on the Juan de Fuca Ridge. A missing, but economically very important, category is the felsic volcanic-hosted polymetallic massive sulfides and related stockworks which are abundant in the ancient geological record, ranging in age from Tertiary (e.g. Kuroko, Japan) through the Paleozoic (e.g. the ore

deposits of western Tasmania) to Archean (e.g. Noranda and Kidd Creek, Canada). These types of deposits formed at (probably) convergent continental margins rather than at mid-ocean ridges, and many represent multi-billion dollar resources. Knowledge of fundamental processes such as fluid-rock interactions, hydrodynamics and structural/tectonic controls on fluid pathways, and metal and fluid sources are key to understanding chemical fluxes and ore deposition.

The thoroughly surveyed, active, PACMANUS hydrothermal field in the Eastern Manus back-arc basin will be the focus of Leg 192, and is the ideal site to address these issues. It lies near the crest (1655-1750 m) of high-standing Pual Ridge, a 40 km-long edifice of dacite/rhyodacite with basal andesite. The hydrothermal field includes two focused, high-temperature “smoker” sites with Cu-Au-rich sulfide deposits, and a field of diffuse, lower temperature venting through intensely altered dacite, for which modeling indicates significant subsurface mineralization. ODP will drill below both focused and diffuse outflow zones, into a likely seawater inflow, and will also drill a “background” reference hole. Plans call for one hole to be CORKed as a geochemical observatory.

Leg 193: Ontong-Java Plateau

The importance of oceanic volcanic plateaus has become widely appreciated by the earth science community in the last several years. Many of these large igneous provinces (LIPs) represent immense volumes of magma erupted on the seafloor in fairly short time periods, and emplacement rates of the largest ones may have approached the entire magma production rate of the global mid-ocean ridge system. In fact, the Alaska-sized Ontong-Java Plateau in the western Pacific may represent the largest igneous event of the last 200 my. The construction of LIPs, and their effects on subduction patterns, continental growth and crust evolution, ocean circulation, and global climate are only beginning to be understood, but are clearly very significant in some cases.

Leg 193 is the first in a proposed two-leg program aimed at understanding the formation of the world’s largest plateau. A transect drill hoes into basement across the Ontong Java Plateau will be drilled to determine its age and duration of emplacement, the range and diversity of magmatism, the environment of eruption and post-emplacment vertical tectonic history of the plateau, the effects of rift-related tectonism, and the paleolatitude of the OJP at the time(s) of emplacement. ❖

Through the Labyrinth of ODP's Proposal Cycle

by *Christina Chondrogianni*

The new submission and evaluation process for ODP proposals was developed by the JOIDES Office in 1997 in consultation with JOI and NSF. The final document was approved by EXCOM in June '97 and was implemented in the fall of the same year. In illuminating the pathways of an ODP proposal through the JOIDES Science Advisory Structure on its way to a scheduled leg, this article aims to provide a better understanding of the evaluation procedure, and to encourage any potential proponent or proponent group not familiar with ODP to undertake the step of designing a new proposal.

The scientific objectives of the Ocean Drilling Program, manifested in the Long Range Plan (LRP), are grouped into two major research themes: Dynamics of Earth's Environment and Dynamics of Earth's Interior. The LRP further identifies in detail the main initiatives and scientific objectives within these two major themes that are significant for scientific ocean drilling. As an ODP proposal needs to meet at least one of these objectives, the LRP provides the basis for the design of any new proposal. This document can be requested either directly from JOI or from the administrative ODP office of any of the member countries or consortia (inside back cover, this issue).

A two-step proposal system consisting first of the submission of a "Preliminary Proposal", and then submission of a "Full Proposal", was introduced as a means by which proponents could get some early and rapid feedback on an idea for scientific drilling before committing to writing a very detailed proposal. "Ancillary Program Letters" form an additional proposal category for projects that can be completed as a supplement to other ODP objectives.

The JOIDES Office acts as a relay station between the proponents and the different evaluation panels and committees of the JOIDES Advisory Structure (Mutti, 1997a). Proposals (Preliminary, Full and Ancillary Program Letters) are submitted to a bi-annual deadline (15 March or 1 October) in a 10-fold copy (plus electronic version) to the JOIDES Office. There, the abstract, scientific objectives and proposed site information are entered into the database, and a cover sheet with all pertinent information is generated. The proposals are then forwarded to the two Scientific Steering and Evaluation Panels (SSEPs) for Earth's Interior (ISSEP) or Earth's Environment (ESSEP).

The Preliminary Proposal — the Short Cycle: Evaluation by the SSEPs

The first step in almost all instances is the submission of a Preliminary Proposal. However, in exceptional cases, such as a narrow window of opportunity to test an exciting, fundamental scientific idea, this new idea can by-pass the Preliminary Proposal stage and be submitted immediately as a Full Proposal.

Preliminary Proposals (≤10 pages) undergo a short evaluation cycle (Fig. 1, gray dashed rectangle). The appropriate SSEP (ISSEP and/or ESSEP) review(s) the proposal based on: the fundamental scientific advances that the proposed drilling might make; its relevance to the Long Range Plan; and the appropriateness of the geographic location and proposed sections drilled to address the scientific objectives of the proposal. If the theme that the proposal addresses falls within the mandate of a PPG (Program Planning Group; Mutti 1997b), it may be forwarded to this group for informational purposes or nurturing.

The results of the review(s) are returned via the JOIDES Office to the contact proponent with one of the following recommendations:

- The proposal does not address high-priority goals of the LRP, or is of low scientific interest. The panel(s) rejects the proposal and recommends that a Full Proposal should not be developed.
- Some specific additional information is needed to evaluate the proposal adequately (e.g. insufficient data to evaluate whether drilling addresses the stated objectives). The panel(s) requests these data from the contact proponent for their next meeting(s). If the data are unavailable and critical, the panel(s) will recommend that a revised Preliminary proposal be submitted once the data are available.
- The proposal addresses objectives for which other proposals exist. The panel(s) refers the preliminary proposal to a PPG, or recommends that the proponents collaborate.
- The proposal is of high priority, but could be improved and made more relevant. In this case, the appropriate SSEP may nurture a proposal (possibly through a watchdog system) and request a revised Preliminary Proposal.
- The proposal is of high interest and well justified. The panel(s) recommends the development of a Full Proposal.

- Is the location selected appropriate to address the scientific problems and hypotheses posed?
- What is the likelihood that the sections drilled will contribute significantly to the solution of the stated scientific problem?
- The Ocean Drilling Program proposals differ in many ways from other science proposals. In particular, because a team of scientists is involved in planning and executing a drilling leg, scientists other than those listed as proponents will be involved with the project. With this in mind, please comment on the competence (e.g., research capability and research record) of the proponents if you feel that it is particularly relevant to the evaluation of the science contained in the proposal. Please explain why you feel that it is relevant.

Keeping strict anonymity of the individual evaluator, the external comments are returned to the JOIDES Office, who distributes them to the contact proponents. They then have the opportunity to comment on the external evaluations in writing a short (≤ 5 pages) Proponent Response Letter (PRL) to be sent, together with the external comments, to the SSEPs.

The Full Proposal — Step 3: Second Evaluation by the SSEPs

Once a proposal is selected for external review, the proponents are asked to submit the site survey data for each drilling site to the Site Survey Data Bank. These are then reviewed by the Site Survey Panel (SSP) to determine their readiness for drilling.

The SSEPs then review the proposal again, taking into consideration the anonymous external comments, the PRL, and the information from the SSP. Based on the scientific priorities of the Long Range Plan, the proposals are then grouped into the following categories:

- I:** Of highest priority for meeting goals of the Long Range Plan
- II:** Important for meeting the goals of the Long Range Plan
- III:** Proposal shows potential, but revision and/or augmentation needed; may require re-review
- IV:** Proposal does not meet ISSEP/ESSEP objectives and is not encouraged further.

These groupings are then sent to the JOIDES Office that accordingly sets up the “Science Prospectus” for the next meeting of the Scientific Committee (SCICOM). The “Science Prospectus” includes all externally evaluated proposals over the last year, as well as any proposals that SCICOM had previously sent forward to OPCOM for possible scheduling.

The Full Proposal — Step 4: Ranking by SCICOM

During the SCICOM meeting, every proposal under consideration is discussed in the presence of the SSEPs Chairs and the SSP Chair. Discussion takes the form of a presentation by the SCICOM watchdog for a given proposal, followed by open discussion among SCICOM members, with input from the SSEPs and SSP Chairs. The proposals are then ranked by SCICOM based on their scientific priority. Once this is completed, a top subset of the ranked proposals is then passed to the Operations Committee (OPCOM) to set up the most efficient ship schedule based on additional considerations, such as weather and current conditions, transit times, logistics, and financial constraints. The proposed schedule of the drilling legs is then voted on by the SCICOM members via electronic communication. Finally, based on the ship schedule, the JOIDES Office prepares the Science Plan for the relevant Fiscal Year.

Proposals that had been forwarded to OPCOM but were not scheduled are kept in the system to be re-ranked by SCICOM the following year, together with all the new, externally evaluated proposals.

Proposals not forwarded to OPCOM are sent back to the proponents, usually with a request for further revision, update and clarification. If this revision results in significant changes in the scientific objectives or site locations, the option exists that they be sent out a second time for external evaluation. The SCICOM Chair informs the contact proponent immediately after the combined SCICOM/OPCOM meeting on the status of the relevant proposal.

The Full Proposal — Step 5: Evaluation by PPSP

Making the schedule is not the end of the story! Every ODP Leg must undergo a review by the Pollution Prevention and Safety Panel (PPSP), typically within 4-8 months after the proposal is scheduled. This requires the preparation of a special review package, and a presentation by the chief proponent or assigned Co-Chief Scientist at a PPSP meeting. Every proposed drill site is reviewed for any type of hazards that could jeopardize the ship or the Program. The safety record of ODP is a testament to the thoroughness with which this is undertaken.

Ancillary Program Letters

Submission of Ancillary Program Letters is encouraged for research investigations that do not address primary scientific objectives to be scheduled as drilling legs, but address supplementary objectives that can be combined with existing drilling projects. These investigations can include collection

of specific shipboard data, seismic experiments, or additional downhole measurements.

Ancillary Program Letters are also submitted to the JOIDES Office and should contain the following information:

- A description of the project and its overall scientific goals;
- The types of shipboard measurements/ data collection necessary;
- The geographic areas of interest;
- The commitment, both in terms of shiptime and shipboard personnel necessary.

These letters undergo the same short evaluation cycle as Preliminary Proposals (Fig. 1). The SSEPs review them and make suggestions for appropriate collaborations with proponents of appropriate existing drilling projects. The JOIDES Office is responsible for initiating the contacts. This must

be done as early as possible in order to successfully integrate ancillary activities and their additional time requirements into the planning for a full drilling leg.

Note: An overview of the proposal cycle and advice on format requirements is available at the JOIDES Office web site (<http://www.whoi.edu/joides/>) — beginning 1 January 1999 at the new web site at Geomar (<http://www.geomar.de/joides/>).

REFERENCES

- Ellins, K., 1997. The external Comment Process. *JOIDES Journal*, 23 (2): pp. 21.
- Mutti, M., 1997a. An overview of the new JOIDES Science Advisory Structure. *JOIDES Journal*, 23 (1): 22-23.
- Mutti, M., 1997b. Un update on current PPGs. *JOIDES Journal*, 23 (2): 22-23. ♦

JOIDES Resolution Operations Schedule: 1999 - 2000

Leg	Destination	Cruise Dates	Port of Origin Dates	Total Days	Transit	On Site
182	Great Australian Bight	13 Oct. - 7 Dec. 1998	Wellington: 8-12 October	56	13	43
183	Kerguelen Plateau	13 Dec. - 10 Feb. 1999	Fremantle: 8-12 December	60	24	36
184	East Asian Monsoon	16 Feb. - 12 Apr. 1999	Fremantle: 11-15 February	56	18	38
185	Izu-Mariana	18 Apr. - 14 June 1999	Hong Kong: 13-17 April	58	14	44
186	West Pacific Seismic Net.-Japan Trench	20 June - 14 Aug. 1999	Tokyo: 15-19 June	56	2	54
	Transit to Dry Dock	18-28 August 1999	Tokyo: 15-17 August	11	11	0
	Dry Dock ¹	29 Aug. - 9 Oct. 1999		42	0	0
186E	HD Engineering Leg	10 Oct. - 9 Nov. 1999		31	20	11
187	Aust.-Ant. Discordance	15 Nov. - 7 Jan. 2000	Sydney: 10-14 November	54	16	38
188	Prydz Bay ²	13 Jan. - 6 March 2000	Fremantle: 8-12 January	54	22	32
189	Southern Gateways ³	12 Mar. - 1 May 2000	Hobart: 7-11 March	51	5	46
189T	Transit	3-16 May 2000	Hobart: 2 May	14	14	0
190	Nankai	22 May - 13 July 2000	Guam: 17-21 May	53	7	46
191	W. Pacific ION	19 July - 11 Aug. 2000	Tokyo: 14-18 July	24	9	15
192	Manus Basin	17 Aug. - 5 Oct. 2000	Guam: 12-16 August	50	10	40
193	Ontong-Java Plateau	11 Oct. - 3 Dec. 2000	Guam: 6-10 October	54	14	40

¹The location of the dry dock will not be known until early 1999.

²Subject to additional finance being found for an ice support vessel.

³A mid-cruise port call is tentatively scheduled for crew rotation.

Scientists who wish to participate in an ODP Leg are encouraged to submit an application via the internet at the web site given below or contact Dr. Tom Davies, Manager of Science Services at ODP TAMU, 1000 Discovery Drive, College Station, TX 77845; (E-mail: tom_davies@odp.tamu.edu). Staffing decisions are made in consultation with the co-chief scientists and take into account nominations from partner countries; final responsibility for staffing rests with ODP at Texas A&M University. Web site: http://www-odp.tamu.edu/sciops/cruise_application_info.html



NEXT ODP PROPOSAL DEADLINE:
15 March 1999!

Proposals should be aimed at furthering the goals of ODP outlined in the Long Range Plan. Detailed information on the process and requirements for proposal submission can be found at: <www.who.edu/joides>.

MARK YOUR 1999 CALENDARS!!!

**INTERNATIONAL CONFERENCE ON
SCIENTIFIC OCEAN DRILLING**

26-29 May 1999

Vancouver, BC., Canada

Objective: To define the scientific objectives for a future multi-platform ocean drilling program with two major vessels. This Conference will target the scientific goals of non-riser drilling and will complement the recent Conference for Cooperative Ocean Riser Drilling (CONCORD) which defined the scientific initiatives for use of a riser-equipped drilling vessel.

**Over 300 Statements of Interest
have been received
for this Conference!!**

Planning is now underway — details will be announced shortly!

**This is YOUR Opportunity to participate in defining
a new program of Scientific Ocean Drilling!**

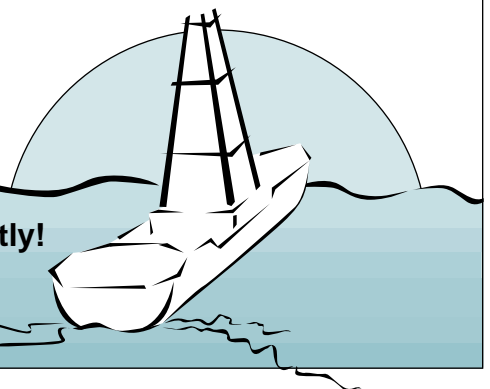

**Visit
the
ODP
booth!**

 **U 10: New Evidence for Rapid Climate Change From Ocean Drilling**

Abundant evidence for rapid and dramatic climatic changes in the geologic past has challenged our understanding of the Earth's climate system and has motivated research into the causes and effects of rapid climate fluctuations. Marking the thirtieth anniversary of scientific ocean drilling, this session will focus on recent contributions of the Ocean Drilling Program to understanding natural climate variability and the causes of rapid climate change. Papers will include studies of high-resolution climate records recovered from anoxic marine basins, sediment drifts, and continental margins and their relations to ice core records, studies of abrupt climatic events (e.g., changes following the K/T boundary; warming at the Paleocene/Eocene boundary), and studies of the consequences of the opening and closing of ocean gateways. The session will highlight the significant advances made possible by ocean drilling in understanding climate and environmental change and will look to new research directions in the future.

- The oral presentation will be on Monday morning and the poster session in the afternoon.

 **OS13: Ocean Drilling in Laminated Sediments for High-Resolution Paleoenvironmental Records**

This session will focus on diverse studies of terrestrial and oceanic conditions through the Holocene and latest Pleistocene as recorded in sediments of Saanich Inlet, a fjord on southern Vancouver Island, and Palmer Deep, an Antarctic shelf basin. The results presented are from the Ocean Drilling Program's (ODP) coring during Leg 169S in the Saanich Inlet in August 1996. For much of the Holocene, Saanich Inlet was an anoxic basin resulting in the accumulation of varved sediments which provide an ultra-high-resolution record (seasonal) of environmental change in the region. Results of investigations into past seismic activity, glaciomarine sedimentary processes, geochemistry, magnetic properties, physical properties, fish and plankton communities, terrestrial vegetation, climate variability, and the role of bacteria and viruses in sediment diagenesis will be presented. The Palmer Deep is a neotectonic inner shelf basin influenced by glacial activity on the Pacific side of the Antarctic Peninsula. The Palmer Deep was drilled with two sites during ODP Leg 178 in March of this year. The record has provided an unprecedented resolution of the Holocene for the Southern Ocean (45 m at site 1098) and has recovered pre-glacial maximum successions (site 1099). The Holocene record has continuously laminated intervals and, on the basis of prior study, contains elements of solar-forced climate variability and productivity changes. Similarity of the Palmer Deep record and the Greenland Ice Sheet Project 2 (GISP2) ice core has already been established for the last 3500 years. The more continuous record will address this correlation in a more rigorous manner. Linkages between the tropical Pacific and the Atlantic might reasonably take place through the Drake Passage, and hence the Palmer Deep may be the best site to evaluate the connection of these two oceanic realms over timescales appropriate to understanding rapid change.

 **OS23: The Subduction Factory**

The MARGINS office and JOI sponsored a Subduction Factory Workshop in June 1998 to encourage researchers interested in convergent margin processes to focus their future research efforts. Participants strongly endorsed work in Central America and recognized the need to study a nonaccretionary convergent margin, as the opposite end member to the accretionary Central American margin. The Mariana, Izu-Bonin, and Tonga systems are all nonaccretionary margins where key forcing functions are distinctly different from those of Central America. At the Workshop, however, the time necessary to evaluate the potential for concentrated efforts in these margins was not available. This special session will draw together presentations of the structure, geochemical cycling, tectonics, volcanology, magma genesis, and general geophysics of these margins. The session is offered in part to permit a larger portion of the marine geological community than was able to be accommodated at the Workshop an opportunity to participate in deliberations related to the MARGINS efforts. A short introduction summarizing the results of the Subduction Factory Workshop will start the session and a 15 minute interval will be held in reserve at the end of the session for a plenary discussion. We hope to schedule a poster session to precede the oral presentations. We plan to schedule a separate room for a longer discussion and planning session to follow the special session. This discussion/planning meeting will be open to all interested.



H06: Fluid Flow in the Earth's Crust

Understanding how fluids move and transport mass and energy in geologic environments is critical to a better understanding of many geochemical and geophysical processes that occur within the Earth's crust. For this session, presentations on large-scale fluid flow that address how this flow affects the geochemical evolution of the crust are solicited. Also, contributions of studies in a variety of geologic settings, including basin evolution, burial metamorphism, regional or tectonically induced metamorphism, plutonic regions and hydrothermal systems are solicited. Presentations on coupled thermal-hydrological-geochemical processes (e.g., the feedback between mineral precipitation/dissolution and porosity/permeability changes) and studies that include both reactive transport modeling and field observations are especially encouraged.



T15: Tectonics and Crustal Structure of Oceanic Plateaus and Arcs

This poster session will focus on the tectonics and crustal-mantle structure of oceanic plateaus and arcs of the western Pacific and other oceans. Crustal structure data will include OBS refraction, deep MCS reflection, and EM results from the Ontong Java, Ogaswara, Shatsky, and other oceanic plateaus as well as data from the Solomon, Izu-Bonin-Marianas, and other oceanic arc systems. These data provide important constraints on the accretion, subduction, and oblique collision of arcs with plateaus, on the crustal growth of plateaus and arcs through magmagenesis, and on the deep crustal and mantle structure of oceanic plateaus and their relation to mantle plumes.

Contact information for each session is available at the AGU web site:

••• <http://earth.agu.org/meetings/> •••

Upcoming Meetings

*** International Workshop on Sediment Transport and Storage in a Coastal Sea-Ocean System, Tsukuba, Japan, 15-19 March 1999.**

The workshop will focus on topics such as

1) roles of marginal seas in global changes, 2) sediment transport from rivers to deep seas and influence of human activities, and 3) strata formation, climate and sea-level changes at Asian continent and island margins. Contact: Y. Saito: • Phone:+81-298-54-3772 • Fax:+81-298-54-3533 •E-mail: yoshi@gsj.go.jp • Information: <http://www.soest.hawaii.edu/margins/meetings.html>

*** EUG 10 Conference, Strasbourg, France 28 March - 1 April 1999.**

The meeting will feature a combination of special symposia and open sessions, covering a full spectrum of the Earth Sciences. Many of the symposia will be interdisciplinary, combining geophysics, geochemistry and geology and emphasizing processes such as oceanic lithosphere and continent-ocean transition zones, origin and evolution of life on earth and past and present climate. Contact: EUG Office; • Phone: +33 (0)3 88 45 01 91 or +33 (0)3 88 41 63 93 • Fax: 33 (0)3 88 60 38 87 • E-mail: eug@eost.u-strasbg.fr • Information: <http://eost.u-strasbg.fr/EUG/EUG10.html>

*** AGU Spring Meeting, Boston, Massachusetts, USA, 1 - 4 June 1999.**

This meeting will cover topics on all areas of geophysical sciences. Deadline: February 18 (postal/express mail) or February 25, 1999 (internet mail). Contact: AGU Meeting Department • Phone: +1-202-462-6900; • Fax: +1-202-328-0566; • E-mail: meetings@kosmos.agu.org • Information: <http://earth.agu.org/meetings/>

*** 10th Ocean Sciences Meeting (AGU/ASLO), San Antonio, Texas, 24 - 28 January 2000.**

This meeting is designed specifically to meet the needs of oceanographers, limnologists, meteorologists, and scientists working in related areas. Subdisciplines for this meeting are atmospheric sciences, estuarine sciences, limnology, oceanography, and ocean technology. Contact: AGU Meetings Department • Phone: 1-800-966-2481 (toll-free in North America), +1-202-462-6900 (in D.C. or outside North America) • Fax: +1-202-328-0566 • E-Mail: meetinginfo@kosmos.agu.org • Information: <http://earth.agu.org/meetings/>

The ESCO Secretariat Moves From Zurich to Stockholm



ESCO is an abbreviation of the ESF Scientific Committee for the ODP and is the 'SCICOM' of the ESF Consortium for Ocean Drilling (ECOD). The Secretariat and the Chair of ESCO rotates every three years between the consortium member countries. After having been at ETH in Zurich, Switzerland, for three years, the Secretariat moved on July 1, 1998 to Stockholm University in Sweden. Nils Holm has replaced Judith McKenzie as ESCO Chair, as well as the ECOD member of SCICOM. Maria Ask, replaces Silvia Spezzaferri as the new ECOD

Science Coordinator, and will have the challenging job of coordinating the Consortium during the first years of Phase III. Consortium members are Belgium, Denmark, Finland, Iceland, Italy, the Netherlands, Norway, Portugal, Spain, Sweden, Switzerland, and Turkey.

Please contact us at:

ESCO Secretariat
Department of Geology and Geochemistry
Stockholm University
S-106 91 Stockholm, Sweden

- Phone: +46-8-16 47 69
- Fax: +46-8-674 78 61
- E-mail: esco@geo.su.se

Thanks & Good Bye!

The WHOI team would like to close this issue of the JOIDES Journal by thanking all those who have contributed over the last two years. Soliciting and obtaining articles was always a challenge when trying to meet a deadline and, on occasion, regretfully resulted in a delay in publication. However, communication and cooperation with each individual was a great pleasure!

In addition, we would like to thank J. Pires, J. Cook and D. Gray (WHOI) for their stoic assistance with design and graphics, as well as J. Ramarui and J. Adams (JOI) for their cooperative help with the printing procedure.

We wish the next JOIDES Journal team at Geomar (Germany) the best of luck with publication of the Journal over the next two years!

The JOIDES Office team at WHOI

REMINDER

JOIDES Office is Moving

Beginning January 1999 the JOIDES Office will be located at:



Research Center Marine Geosciences
Wischhofstr. 1-3, Building 4
24148 Kiel, Germany
E-mail: joides@geomar.de
Web site: <http://www.geomar.de>